

SVAB

Precision Control Systems

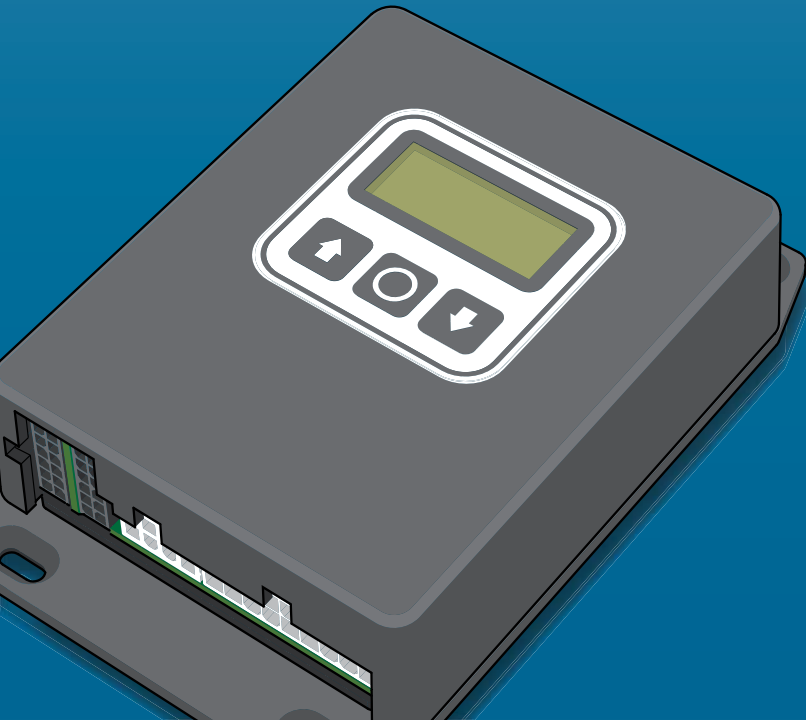

GP CONTROLLER

User Manual

GP CONTROLLER



User Manual

User Manual for GP Controller (GPC)
Version 2.5 (151008)

Art.nr: 630013

This work is protected by the Copyright Act and may not be copied, distributed or amended. Failure to comply with this Act can result in prosecution and fines, imprisonment or an obligation to pay compensation to the author/owner.

Table of Contents



1. Introduction	9
1.1 Analog Axis	10
1.2 Digital Input Signals	10
1.3 Input	11
1.4 Output	11
1.5 Valves	12
1.6 Hydraulic function	12
1.7 Proportional controller	12
1.8 Summary	13



2. Installation	14
2.1 Assembly example 1. 4-function system for forklifts	15
2.2 Assembly example 2. Control of the rotor tilt and wheels/tracks	16
2.3 Example 3. Control of backhoe loader	18
2.4 Start-up settings	20



3. User Interface	23
3.1 Operating Mode	24
3.2 Language Setting	24
3.3 Main Menu	25
3.4 Master mode menu	26



4. Main Menu Summary	27
4.1 End Levels	28
4.2 Start Levels	28
4.3 Feeder Settings	28
4.3.1 Feeder End Levels	28
4.3.2 Feeder's Start Level	29
4.3.3 Feeder's Max Level	29
4.3.4 Feeder's Fixed Levels	30
4.3.5 Ramp Time	30
4.3.6 Derivation	31
4.3.7 Feeder's Middle Level	31
4.4 Information	32
4.4.1 Firmware Version	32
4.4.2 Serial Number	32
4.4.3 Display Stored Error Codes	32
4.4.4 Delete Stored Error Codes	33
4.5 Middle Levels	33
4.6 Ramp Time	34
4.7 Progressive Curve	34
4.8 Lever Calibration	35
4.9 Change Direction	35
4.10 Copy Banks	35
4.11 Enter Code	36
4.12 Unlock Menus	36



5. Master Mode Menu Summary..... 37

- 5.1 Logic 38
 - 5.1.1 In-test 38
 - 5.1.2 Functions..... 38
 - 5.1.3 Outputs 39
 - 5.1.4 Double push..... 39
- 5.2 Output types 40
- 5.3 Rippel amplitude..... 40
- 5.4 Lever Calibration..... 40
- 5.5 Hysteresis..... 41
- 5.6 Erase EEPROM..... 41
- 5.7 Buzzer 41



6. Output Types 43

- 6.1 Output types 44
- 6.2 Feeder outputs 45
- 6.3 Current monitoring..... 47



7. Logic Programming 49

- 7.1 In-test..... 50
- 7.2 Programing functions..... 51
- 7.3 To program a feeder..... 58
- 7.4 Double push..... 59
- 7.5 Import functions 60
- 7.6 Control a function with a function..... 61

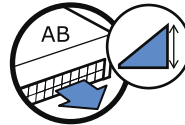

8. Adjustment Instructions..... 63

- 8.1 Set the Feeder's Middle Level..... 64
- 8.2 Feeder's Start level 65
- 8.3 Feeder's End Levels..... 66
- 8.4 Feeder's Fixed Levels..... 67
- 8.5 Feeder's Max Level..... 68
- 8.6 Middle Levels..... 69
- 8.7 Start Levels..... 71
- 8.8 End Levels 72



9. Optional Settings..... 73

- 9.1 Lever Calibration..... 74
- 9.2 Hysteresis..... 76
- 9.3 Progressive Curve 77
- 9.4 Ramp Time 78
 - 9.4.1 Ramp time, proportional outputs.. 78
 - 9.4.2 Ramp time, on/off outputs 79
- 9.5 Ripple Amplitude..... 81
- 9.6 Change Direction 82
- 9.7 Derivation..... 82
- 9.8 Buzzer..... 83
- 9.9 Enter Code..... 84
- 9.10 Unlock Menus 85
- 9.11 Change the Code..... 85
 - 9.11.1 Deactivate Menu Lock..... 85

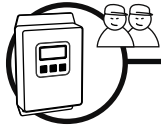

10. Configuration Banks	87
10.1 Current Configuration Bank	88
10.2 Change Configuration Bank.....	88
10.3 Copy Banks	88



11. Troubleshooting	91
11.1 Input Signal Error	92
11.2 System Error	92
11.3 Output Error	93
11.4 CAN-error	93
11.5 Show Stored Error Codes	94
11.6 Erase Stored Error Codes	94
11.7 Erase EEPROM	95
11.8 Serial Number	95
11.9 Firmware Version	95

Appendix 1. Connections	96
Appendix 2. Common Default Settings.....	97
Appendix 3. Default Settings Banks A, C, D and E	98
Appendix 4. Default Settings Bank B	100
Appendix 5. Set Up Example: Excavator with tiltrotator and extra function (1)	102
Appendix 6. Set Up Example: Excavator with tiltrotator and extra (2)	104
Appendix 7. Set Up Example: Excavator with tiltrotator, grapple and extra	106
Appendix 8. Set Up Example: Excavator with tiltrotator, grapple, extra and tracks	108
Appendix 9. Set Up Example: Excavator with tiltrotator, grapple, extra and wheels	110
Declaration of Conformity	112
MENU REGISTER	114



1. Introduction

What is GP Controller?

GP Controller (GPC) is a control unit designed for flexible and safe proportional control of many types of processing machines.

The GPC has I/O ports that can be configured for variable control of most machines and by different operators.

This chapter explains the symbols used in this manual and shows how a control system is setup.

Instructions:

1. Read through the chapter to get a general idea of the system.
2. Continue on to chapter 2.

Chapter:

1.1 Analog Axis	10
1.2 Digital Input Signals	10
1.3 Input	11
1.4 Output	11
1.5 Valves	12
1.6 Hydraulic function	12
1.7 Proportional controller	12
1.8 Summary.....	13

Page:

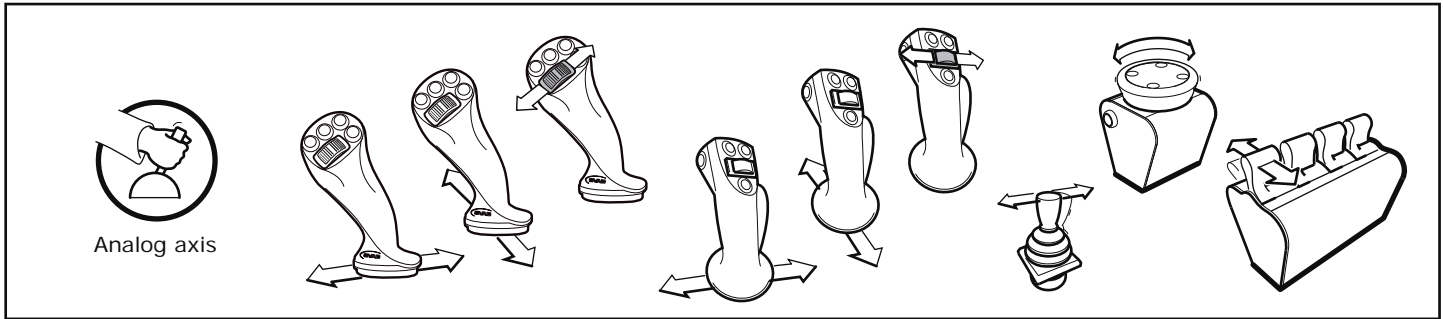

1.1 Analog Axis

Above are examples of input devices which move along analog axes. Input devices move in two directions, A or B, which the GPC refers to as Ax1, Ax2 etc. Devices have two input signal contacts and at most 7 analog axes can be connected to a GPC, with the left-hand input signals designated as Ax1-Ax4 and the right-hand input signals as Ax5-Ax7.

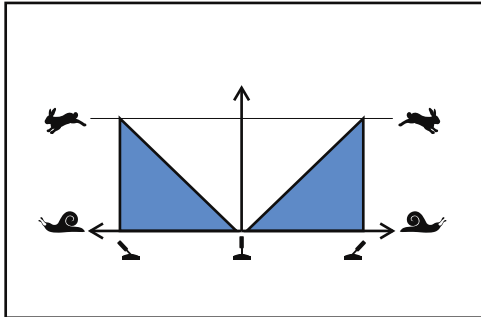

By using an analog axis you can regulate the speed of a hydraulic function in both its directions.

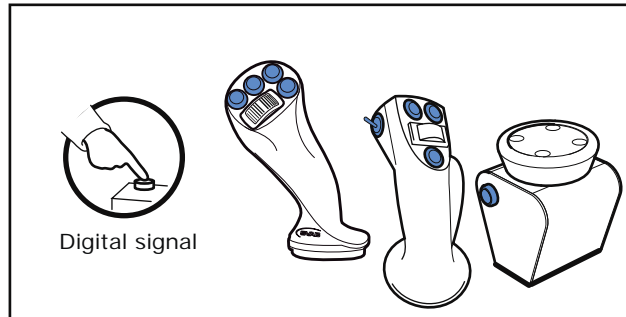

1.2 Digital Input Signals

Buttons and switches are examples of digital input signals, which the GPC refers to as DIN1, DIN2 etc. At most 8 digital inputs can be connected via the input connectors, with the left-hand input signals designated as DIN1-DIN4 and the right-hand input signals designated as DIN5-DIN8.

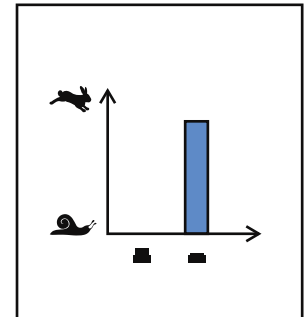

A digital input can only start/stop a hydraulic function. The speed is preset.

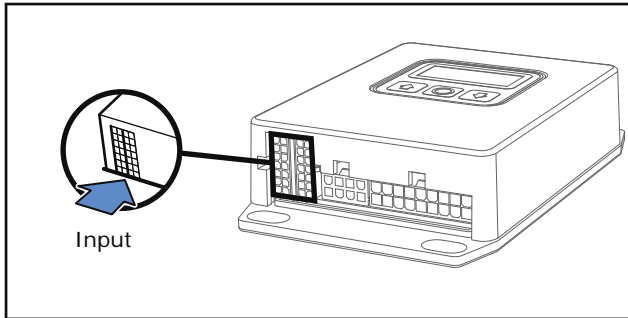

1.3 Input

The GPC has a 15-pin input divided into left and right-hand input contacts. Both analog axes and digital inputs can be connected. For more information about input, see Appendix 1.

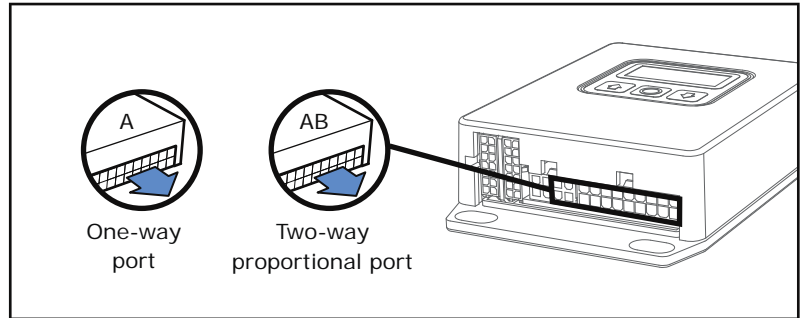

1.4 Output

The output regulates the amperage to the magnetic coils in the valves. The GPC has 9 outputs, 5 two-way proportional outputs and 4 one-way on/off outputs. For more information about output, see Appendix 1.

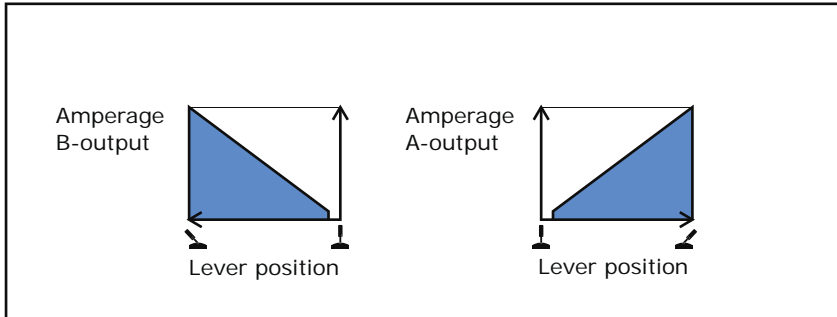

The two-way proportional outputs are called Out1-Out5. They control two-way proportional valves, each consisting of an A-output and a B-output, one for each direction. Proportional control uses amperage to regulate how much the valve opens, permitting variable control of hydraulic cylinder speed.

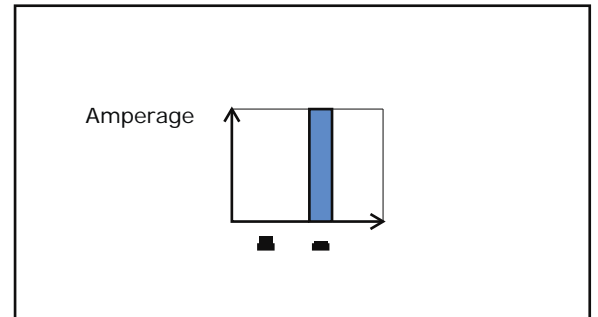

The one-way outputs are called Out6-Out9. These can only control one-way on/off-valves i.e., valves that can only open or close.

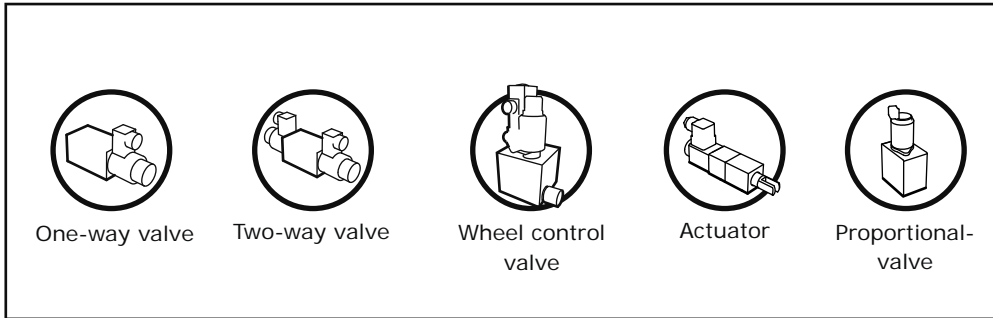

1.5 Valves

Various valves which can be connected to and controlled by the GPC's output.

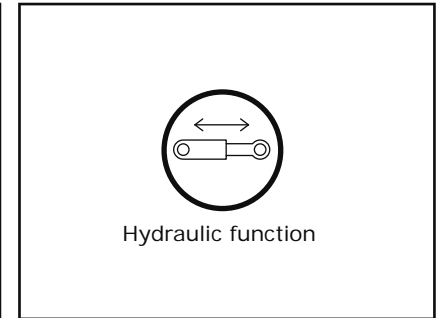

1.6 Hydraulic function

Valves control the hydraulic functions, e.g. a hydraulic cylinder or a hydraulic motor.

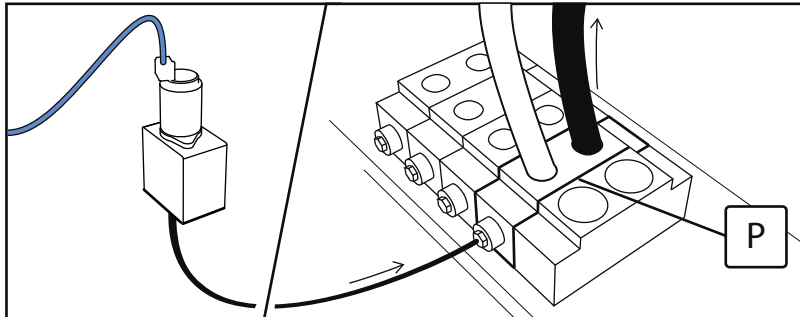

1.7 Proportional controller

A proportional controller (or feeder) consists of a proportional shuttle valve (or actuator) which is connected to a valve on the machine's valve block (P). It supplies the total amount of oil needed by an attachment with several hydraulic functions e.g., a tilt-rotator on an excavator.

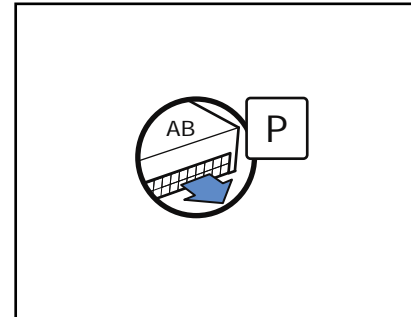

The GPC uses feeder output to control the feeder via Out4 or Out5.

1.8 Summary

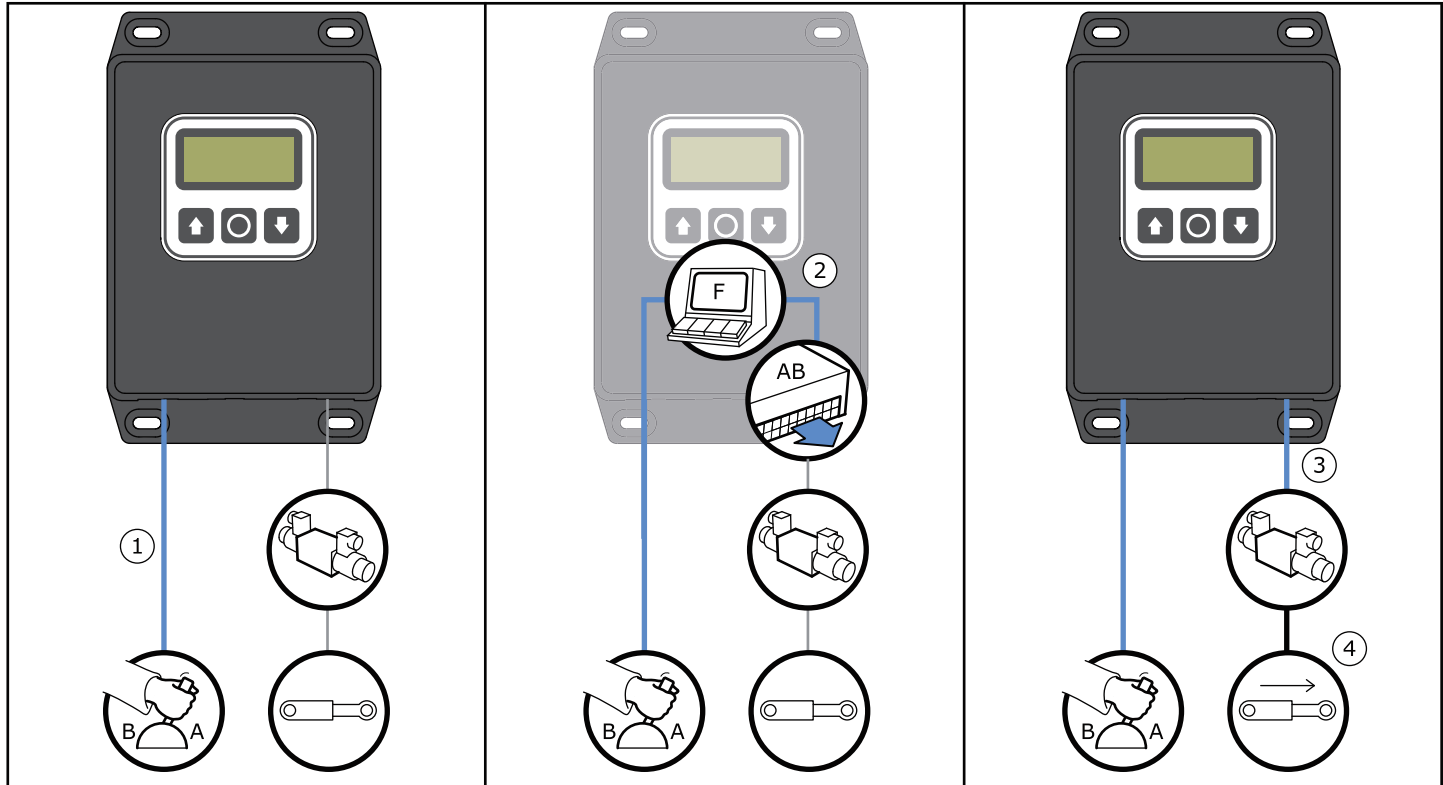

1. An analog axis is linked to the GPC. When the axis is activated the input receives the input signal.

2. A function links the input signal with the output to be controlled. (The GPC has 12 programmable functions, read more about these in chapter 5. *Master Mode Menu Summary*)

3. The output sends current to the valve.
4. The valve opens and releases oil pressure which causes the hydraulic cylinder to move.



2. Installation

General:

This chapter contains general instructions on how to install a control system. The assembly instructions are not adapted to any specific machine type or manufacturer.

The chapter includes four examples showing how a system can be configured and the necessary parts to be installed.

Instructions:

1. Assemble the system in accordance with one of the assembly examples or the supplied assembly instructions, if available.
2. Perform the start-up settings.
3. Continue to chapter 3.

Chapter:

Page:

2.1 Assembly example 1. 4-function system for forklifts	15
2.2 Assembly example 2. Control of the rotor tilt and wheels/ tracks	16
2.3 Example 3. Control of backhoe loader	18
2.4 Start-up settings.....	20

2.1 Assembly example 1. 4-function system for forklifts

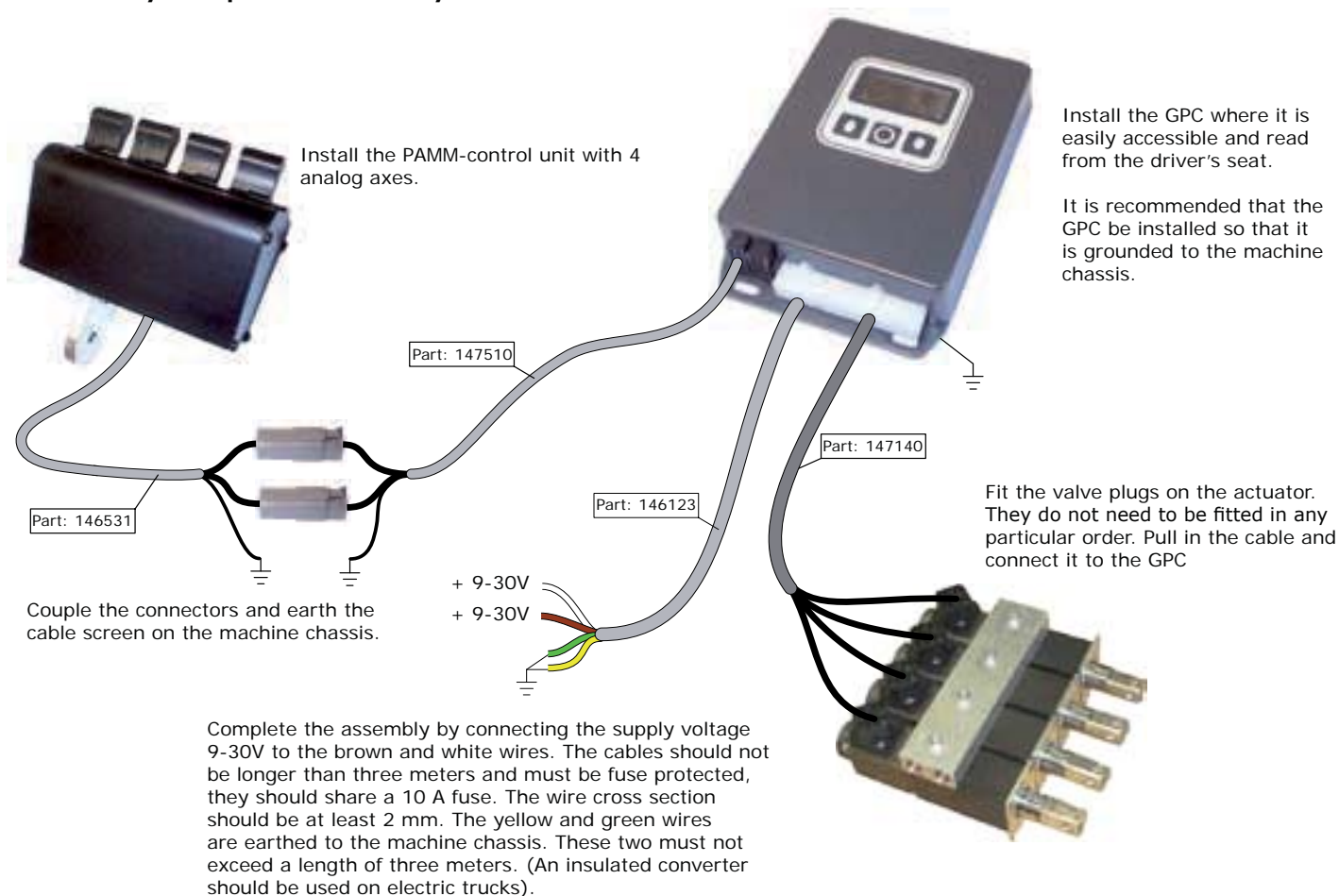

2.2 Assembly example 2. Control of the rotor tilt and wheels/tracks

The SVAB Grip L8 lever replaces the machine's standard lever and it is available in many configurations. This model has 2 analog axes (rollers) and 7 digital input signals (buttons).



Install the GPC where it is easily accessible and read from the driver's seat.

The GPC must be grounded to the machine chassis.



Part: 147100

Part: 200183

Part: 146108

Part: 146120

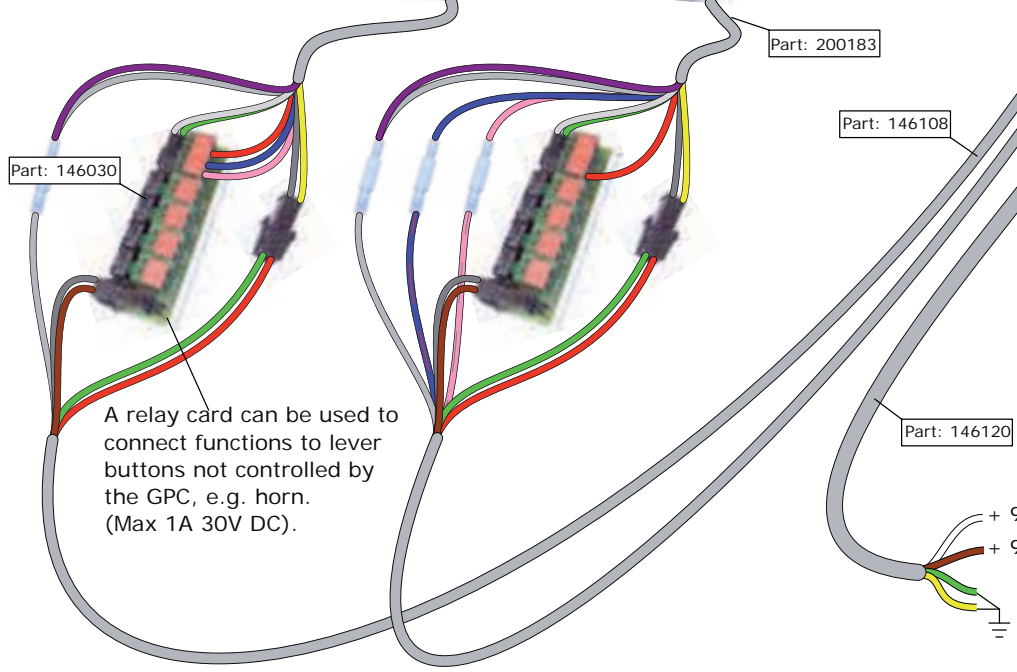

Part: 146030

A relay card can be used to connect functions to lever buttons not controlled by the GPC, e.g. horn. (Max 1A 30V DC).

Complete the assembly by connecting the supply voltage 9-30 V to the brown and white wires. The cables should not be longer than three meters and must be fuse protected by a 10 A fuse. The wire cross section should be at least 2 mm. The yellow and green wires must both be grounded to the machine chassis and not exceed three meters.

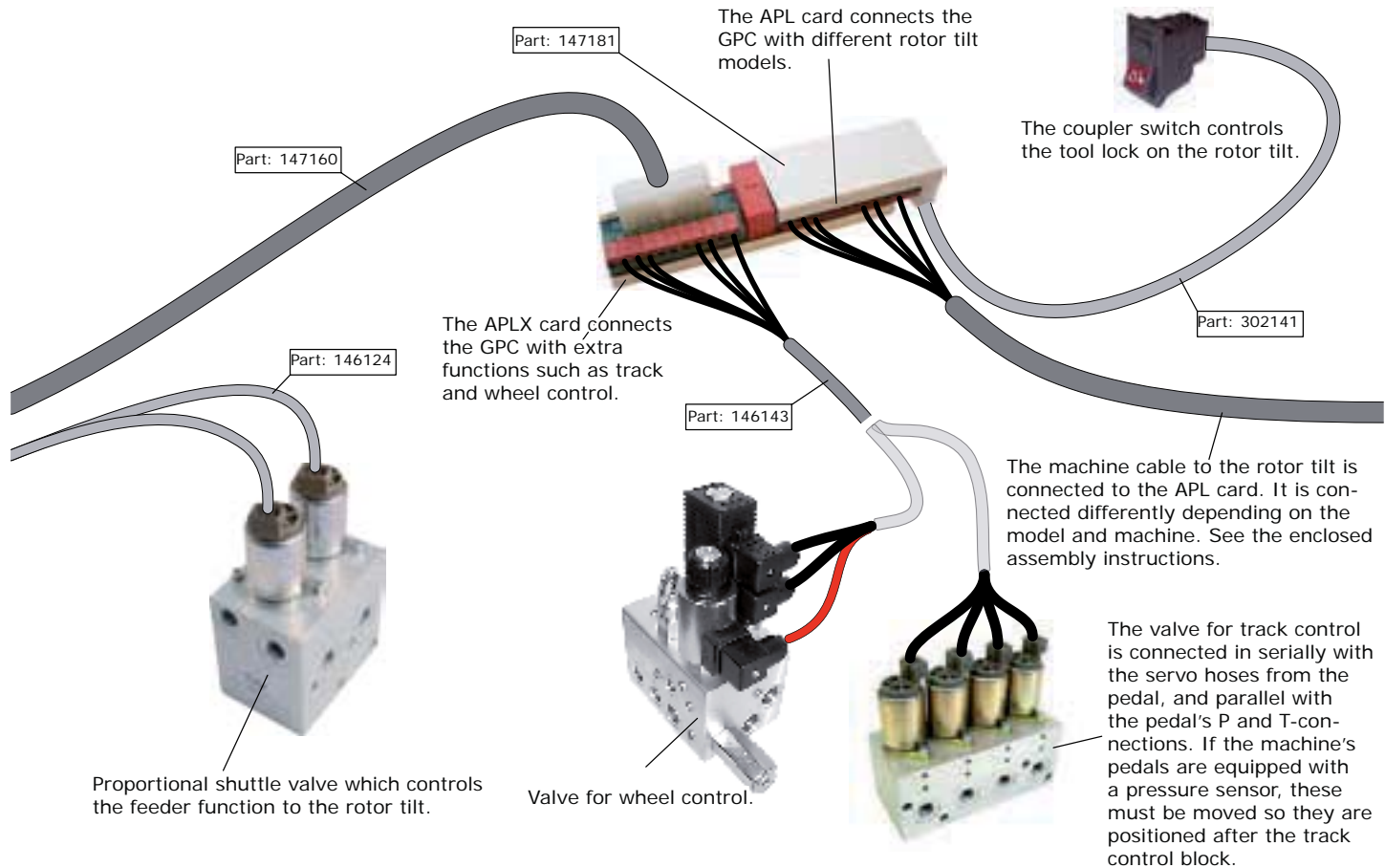

2.3 Example 3. Control of backhoe loader

This example shows how a customised control system can look like for complete control of a backhoe loader. This is not intended to be an assembly instruction.

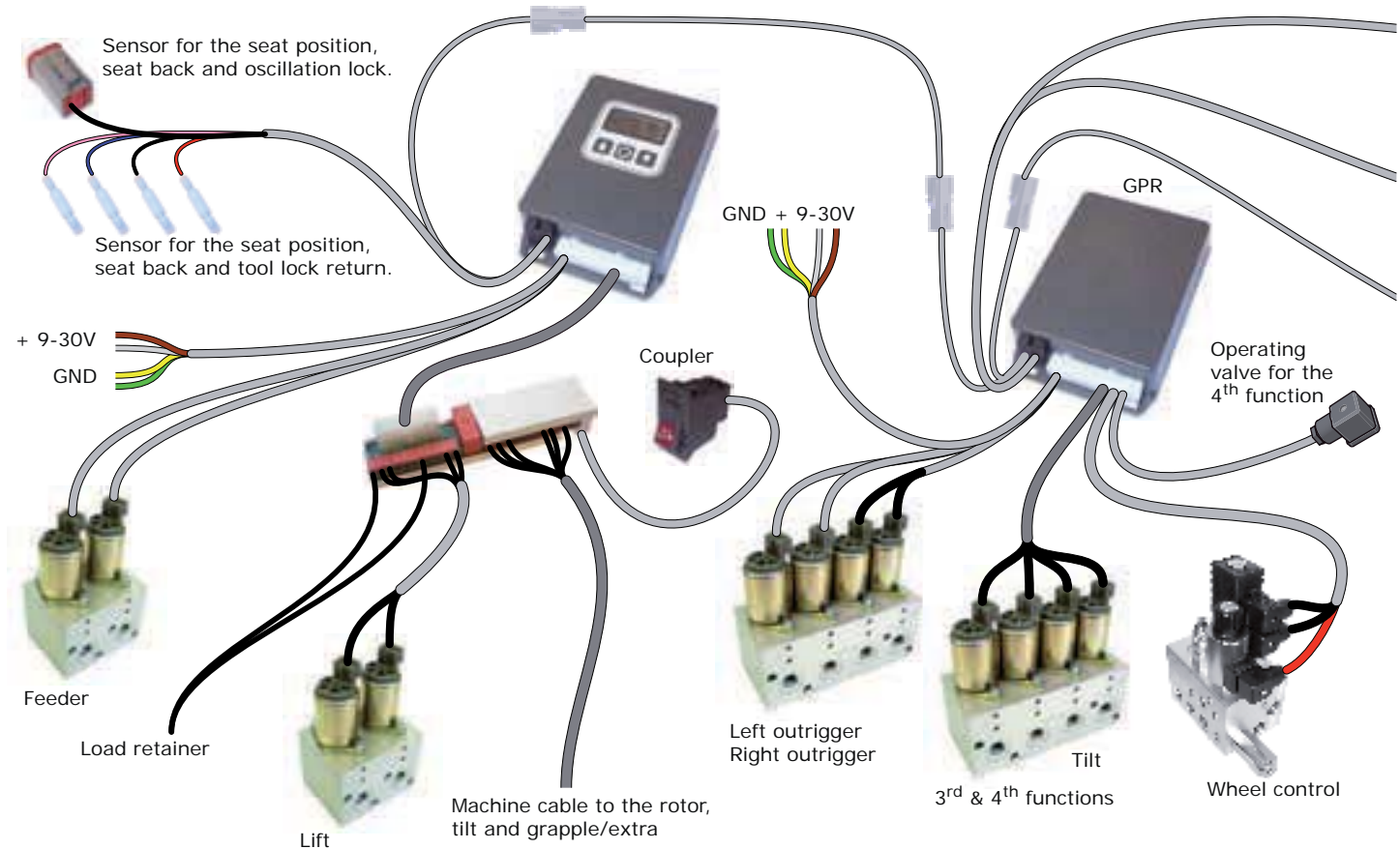

2 Prof1 levers with base. Including 7 analogue axis and 11 digital input signals.

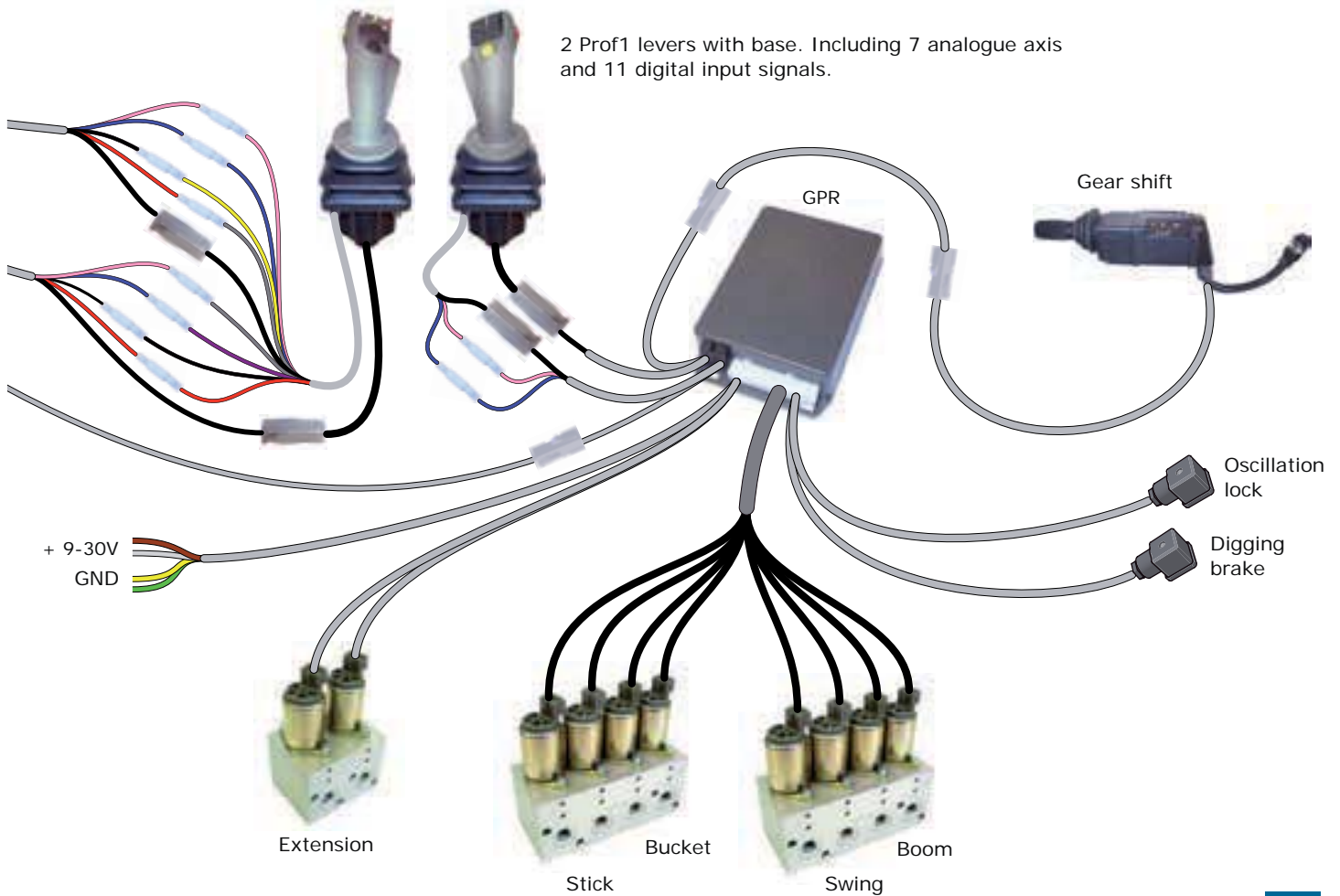

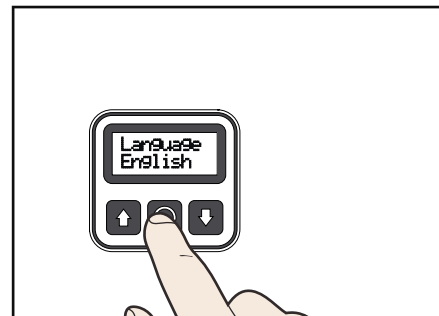

2.4 Start-up settings

The first-time the GPC is powered on, several basic settings needs to be made. The first step is to select the language.

1. Select the preferred language using the arrow keys. English and Swedish is currently available.

2. Save and continue by pressing the middle button.

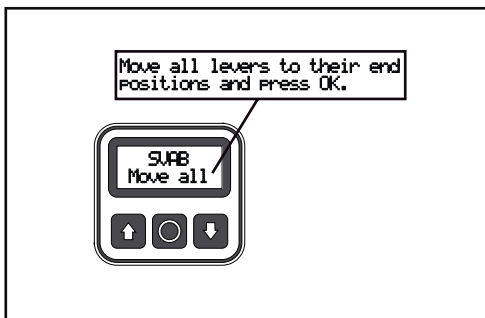

In the next step all the analog axes are calibrated. This is always done the first time a lever is connected and allows the GPC to control the signal type and various values which the lever will control.

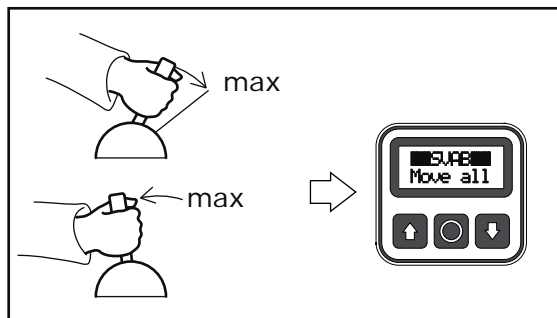

3. Slowly pull all levers (e.g. rollers) forwards and backwards to their end positions. Continue until the black squares on the display stop flashing.

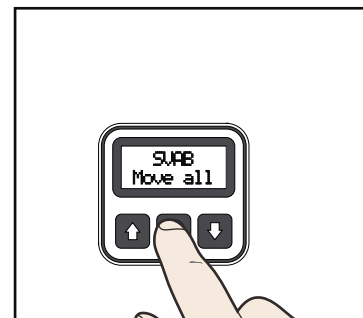

4. Continue by pressing the middle button.

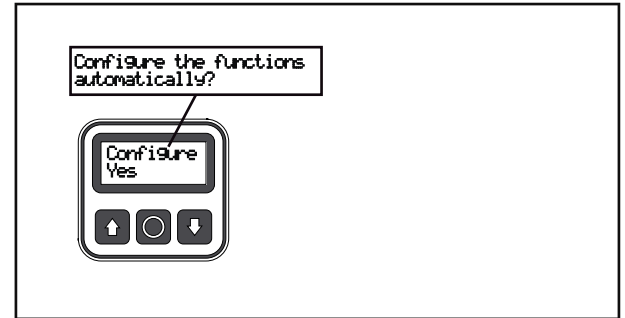
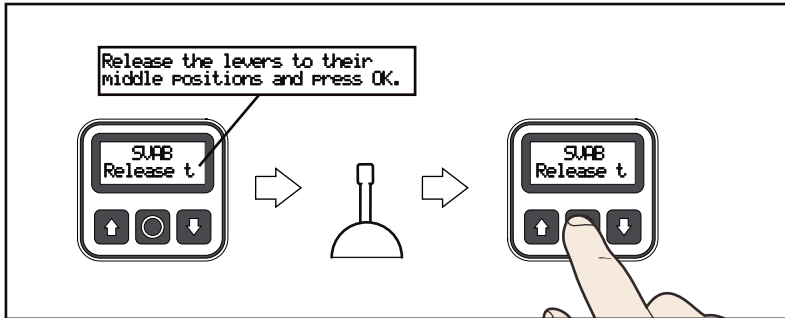

5. Release all levers so that they are in their middle positions and then press the middle button to complete calibration. (If calibration should fail or needs to be repeated, read chapter 9.1 *Lever Calibration*)

In the last start-up setting you select whether you would like the GPC to configure the functions automatically.

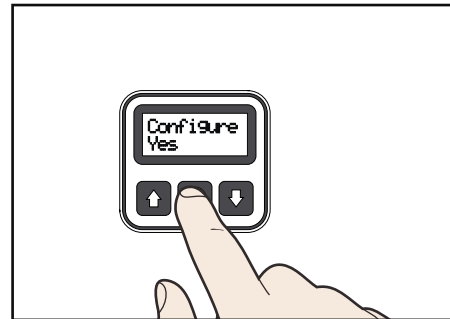
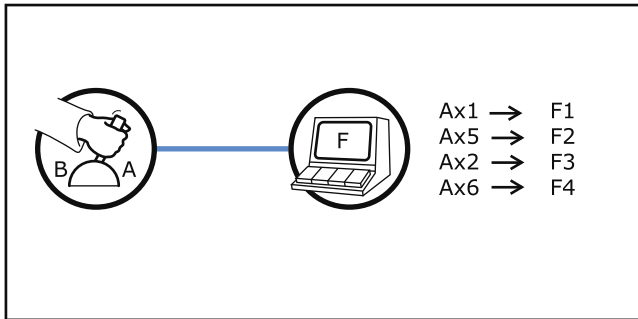

Automatic configuration of functions involves all connected levers being linked to individual functions. The example above describes how a system with four analog axes can be programmed. (How to program GPC functions and what is involved is described in chapter 7. *Logic Programming*.)

6. Press the middle button to accept the automatic configuration and exit the start-up settings.



3. User Interface

General:

Now that the system has been started, it is a good idea to familiarize yourself with the GP Controller's (GPC) user interface, before additional settings are made.

The GPC interface consists of a display and three buttons. The display shows the setting options and your position in the menu system. To scroll menus and sub-menus, use the arrow keys. To select an option, use the middle button.

Instructions:

1. Acquaint yourself with the GPC's overall menu system. (See chapters 4. *Main Menu Summary* and 5. *Master Mode Menu Summary* for more in-depth description.)
2. Continue to the next chapter.

Chapter:

3.1 Operating Mode	24
3.2 Language Setting	24
3.3 Main Menu	25
3.4 Master mode menu	26

Page:

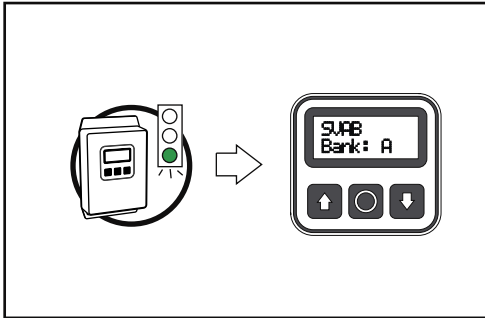

3.1 Operating Mode

The machine can be controlled when the system is in the operating mode.

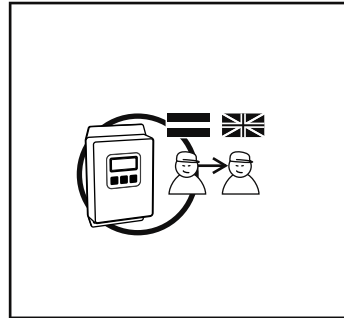

3.2 Language Setting

The GPC has several available languages, which may be chosen in the language menu.

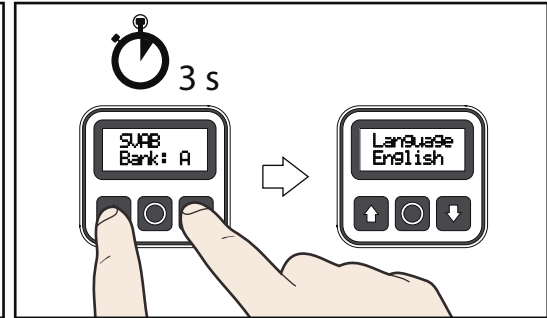

1. To access the language menu and change the language, press both arrow keys for approximately 3 seconds and release.

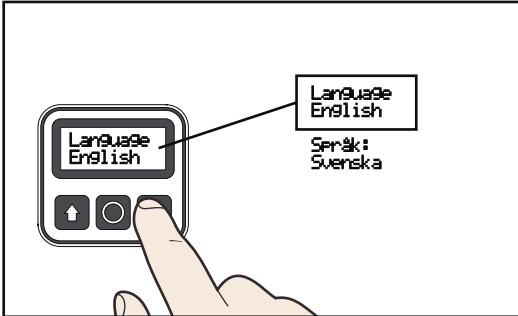

2. Use the arrow keys to scroll through the available languages. Currently English and Swedish is available.

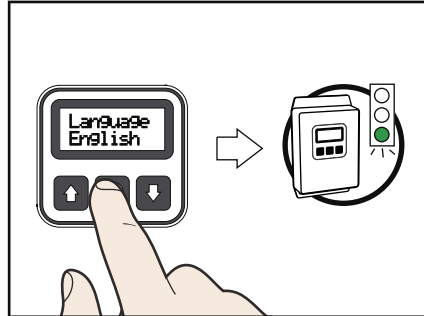

3. Use the middle button to confirm language choice and return to operating mode.

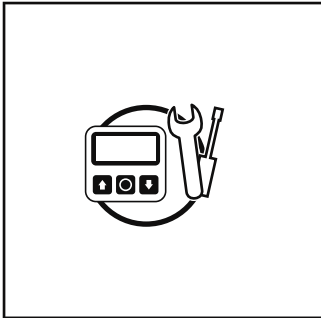

3.3 Main Menu

Settings are made in the main menu to adapt the system to the machine.

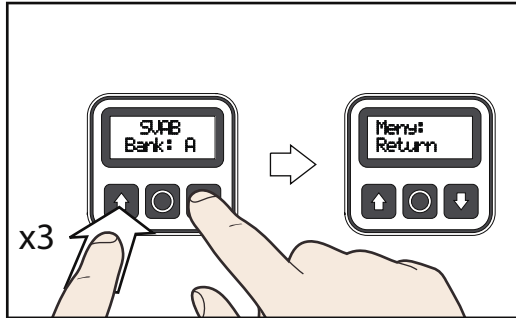

1. To access the menu, hold the down arrow while at the same time pressing the up arrow three times.

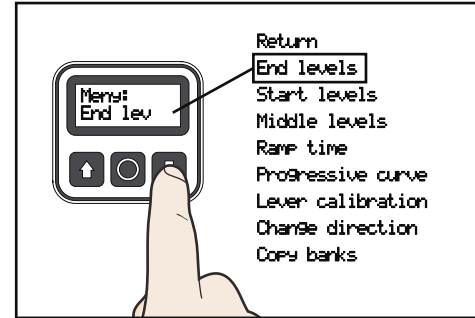

2. To scroll down through the menu, press the down arrow.

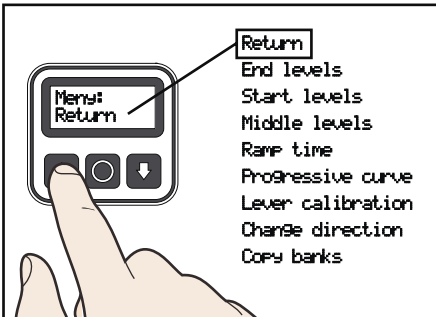

3. To scroll up through the menu, press the up arrow.

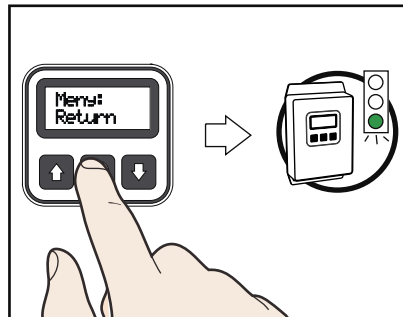

4. To return to the operating mode, scroll to "Return" and press the middle button.

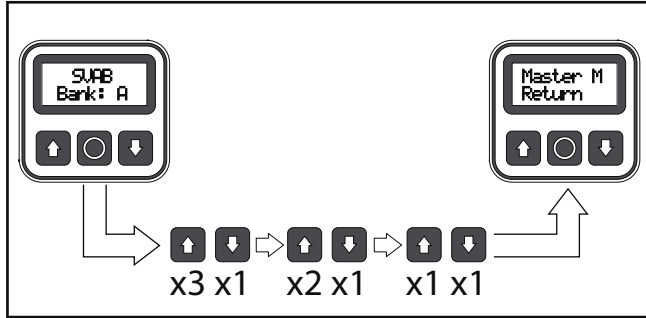
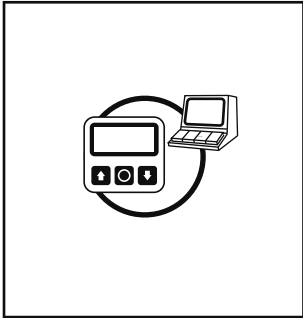

3.4 Master mode menu

The master mode menu is used to make advanced settings and meant for service technicians.

To enter the master mode menu, press the arrow keys according to the above combination.

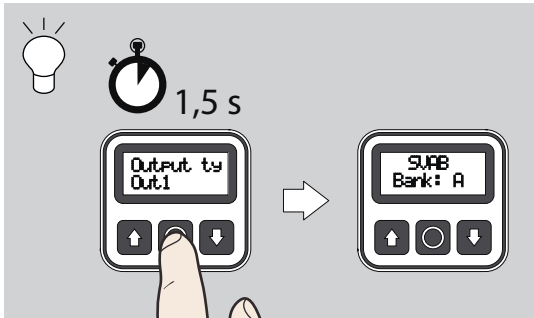

No matter where you are in the system, holding the middle button for 1.5 sec returns you to the operating mode.

Note: Changes made in the current mode will not be saved.



4. Main Menu Summary

How is the main menu used?

To modify the GP Controller system (GPC) to a particular machine, settings are made in the main menu.

Instructions:

1. Read the chapter text thoroughly and follow the main menu in your own GPC.

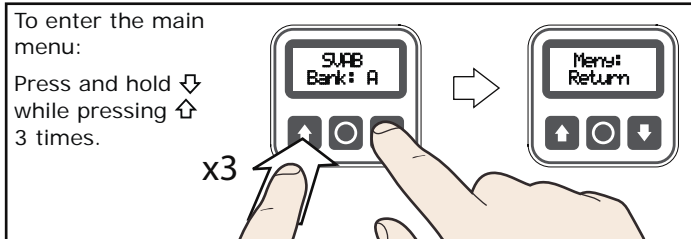



Tip!

Note that the sub-menus in the main menu in this chapter have the same order as in your GPC.

Chapter:

Page:

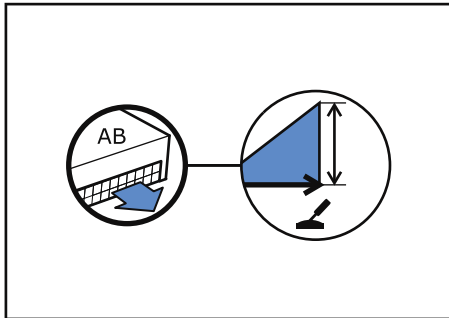
4.1 End Levels	28
4.2 Start Levels.....	28
4.3 Feeder Settings	28
4.3.1 Feeder End Levels.....	28
4.3.2 Feeder's Start Level	29
4.3.3 Feeder's Max Level.....	29
4.3.4 Feeder's Fixed Levels.....	30
4.3.5 Ramp Time	30
4.3.6 Derivation.....	31
4.3.7 Feeder's Middle Level	31
4.4 Information.....	32
4.4.1 Firmware Version	32
4.4.2 Serial Number	32
4.4.3 Display Stored Error Codes	32
4.4.4 Delete Stored Error Codes.....	33
4.5 Middle Levels.....	33
4.6 Ramp Time	34
4.7 Progressive Curve	34
4.8 Lever Calibration.....	35
4.9 Change Direction	35
4.10 Copy Banks	35
4.11 Enter Code	36
4.12 Unlock Menus	36





- Return
- End levels**
- Start levels
- Feeder settings
- Information
- Middle levels
- Ramp time
- Progressive curve
- Lever calibration
- Change direction
- Copy banks

4.1 End Levels

An end level is the signal level that is sent from the output to the valve when the associated analog axis is in its end position.

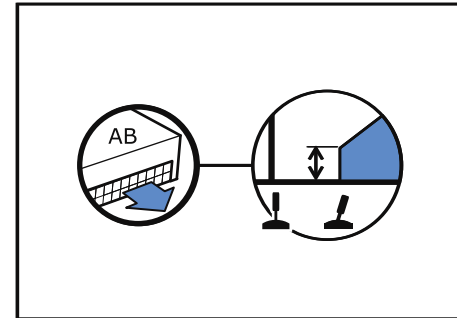
"End levels" in the main menu. To set an end level see chapter 8.8 *End Levels*, page 72.



4.2 Start Levels

A start level is the signal level sent to the valve from the output when the associated analog axis is in its start position.



- Return
- End levels
- Start levels**
- Feeder settings
- Information
- Middle levels
- Ramp time
- Progressive curve
- Lever calibration
- Change direction
- Copy banks

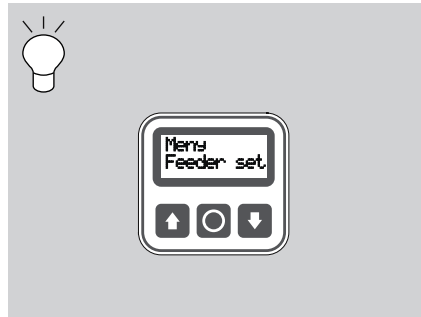

4.3 Feeder Settings

When an output is set to be a feeder, the option "Feeder settings" is added to the main menu.

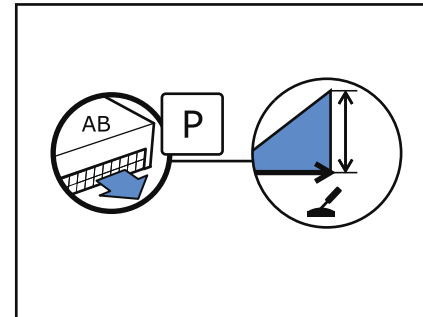

4.3.1 Feeder End Levels

An end level is the signal level sent from the feeder output to the feeder when the lever is in its end position.

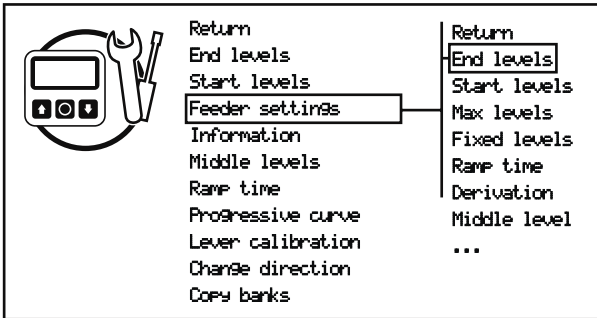

"End levels" is a submenu to "Feeder settings" in the main menu. To set an end level see chapter 8.3 *Feeder's End Levels*, page 66.

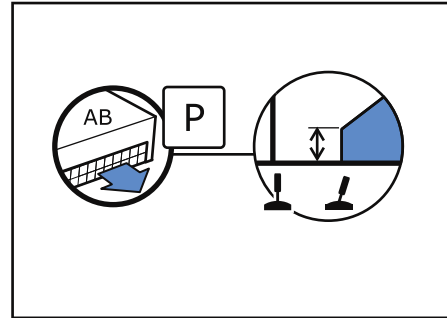

4.3.2 Feeder's Start Level

The feeder's start level is the signal level sent to the feeder when a lever is pulled to its start position.

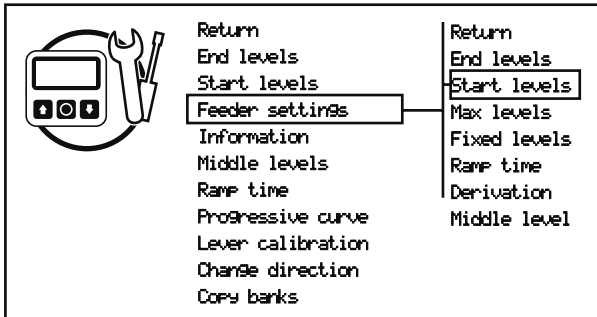

"Start level" is a submenu to "Feeder settings" in the main menu. To set a start level see chapter 8.2 *Feeder's Start level*, page 65.

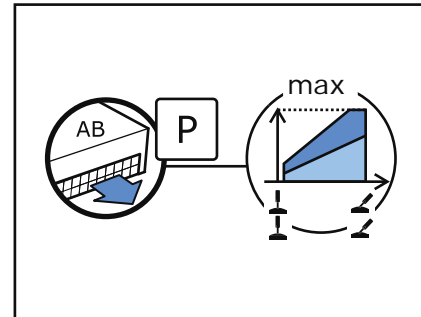

4.3.3 Feeder's Max Level

The max level determines how much the feeder opens if several outputs are used simultaneously.

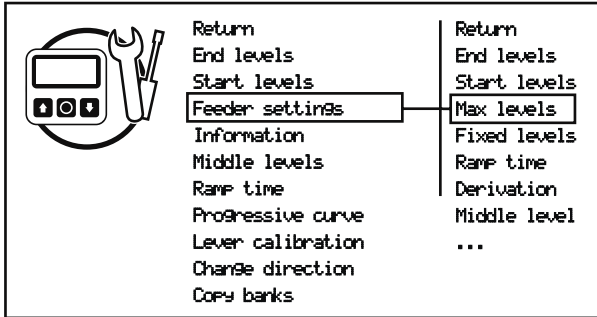

"Max levels" is a submenu to "Feeder settings" in the main menu. To set a max level see chapter 8.5 *Feeder's Max Level*, page 68.

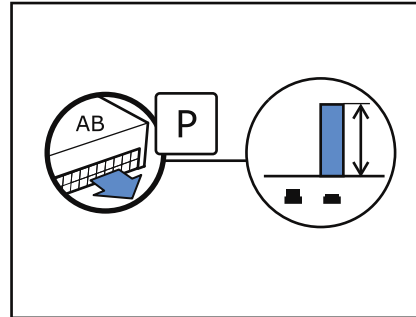

4.3.4 Feeder's Fixed Levels

The feeder's fixed levels are the signal levels that emit from the feeder output when a digital input signal activates the feeder.

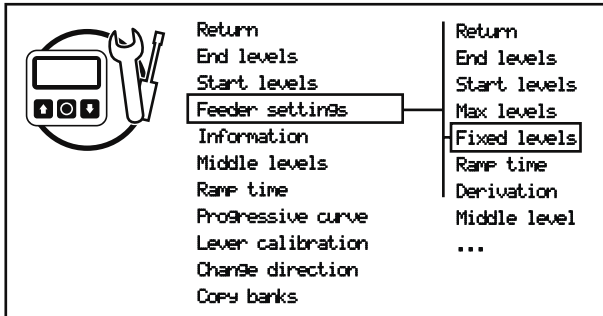

"Fixed levels" is a submenu to "Feeder settings" in the main menu. To set a fixed level see chapter 8.4 *Feeder's Fixed Levels*, page 67

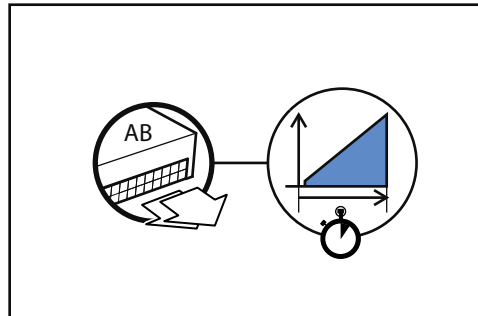

4.3.5 Ramp Time

Ramp time is the time it takes for the signal from one output to go from start level to end level when the lever is moved from the middle position to the end position.

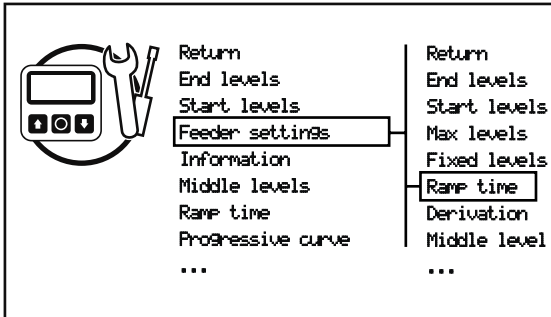

"Ramp Time" is a submenu to "Feeder settings" in the main menu. To set a ramp time see chapter 9.4 *Ramp Time*, page 78.

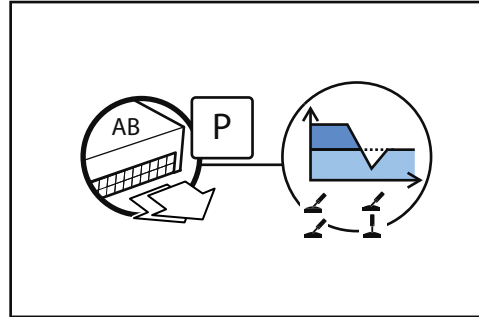

4.3.6 Derivation

Oversteer is used to make the feeder control return faster when a lever is moved back. The oversteer is set using a derivation factor.

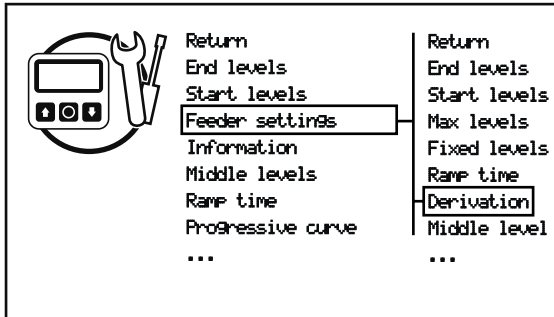

"Derivation" is a submenu to "Feeder settings" in the main menu. To set the derivation factor see chapter 9.7 *Derivation*, page 82

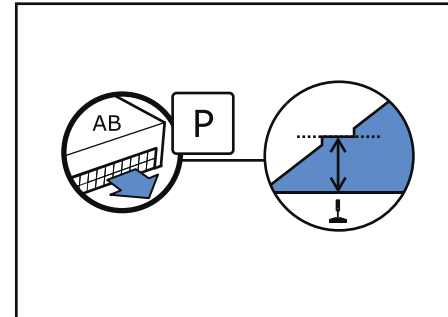

4.3.7 Feeder's Middle Level

The middle level is the signal level sent from the feeder output to the feeder's actuator when all analog axes are in their middle positions.

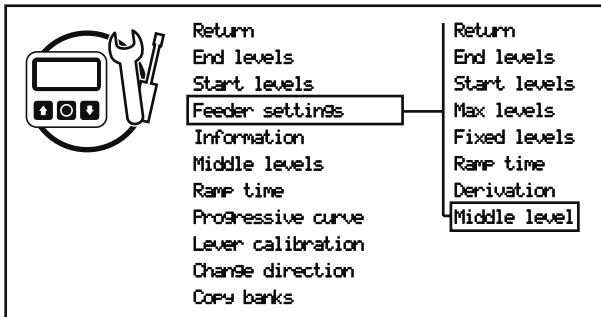

This menu option is only shown if an actuator feeder is present. "Middle level" is a submenu to "Feeder settings" in the main menu. To set a middle level see chapter 8.1 *Set the Feeder's Middle Level*, page 64.

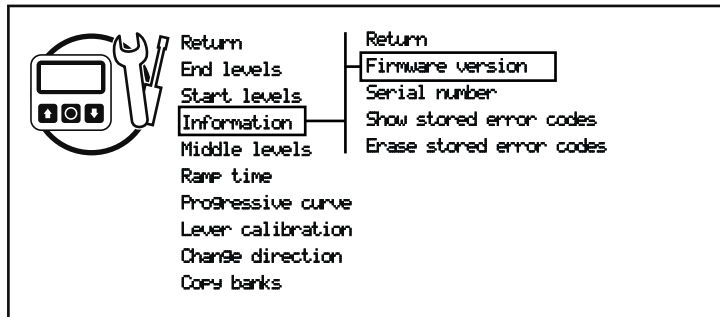

4.4 Information

"Information" is found in the main menu.

4.4.1 Firmware Version

Displays the firmware version and the distribution date of the GPC. "Firmware version" is a submenu to "Information" in the main menu. See also chapter 11.9 *Firmware Version*, page 95.

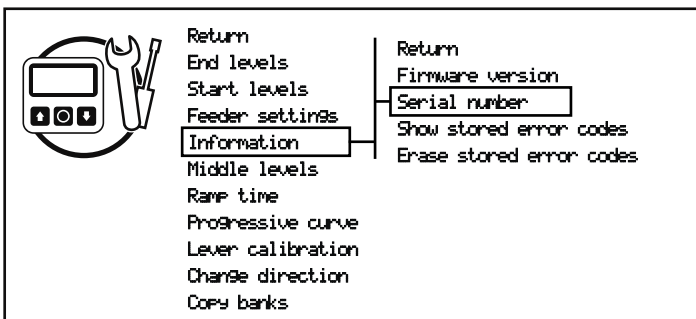

4.4.2 Serial Number

The GPC's serial number can be displayed by selecting the submenu "Serial number" under "Information" in the main menu. See also chapter 11.8 *Serial Number*, page 95.

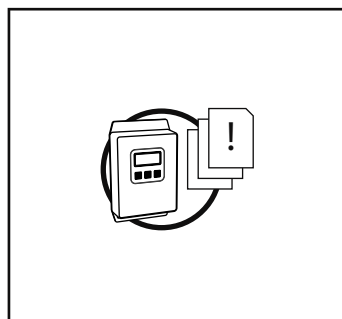

4.4.3 Display Stored Error Codes

Up to 10 error codes are stored in order to facilitate trouble shooting.

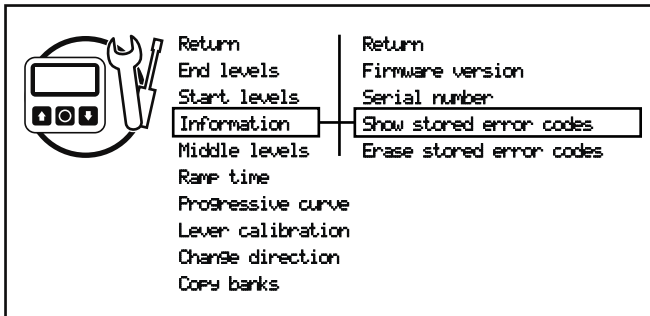

"Show stored error codes" is a submenu to "Information" in the main menu and is used to view the stored error codes. See also chapter 11.5 Show Stored Error Codes, page 94.

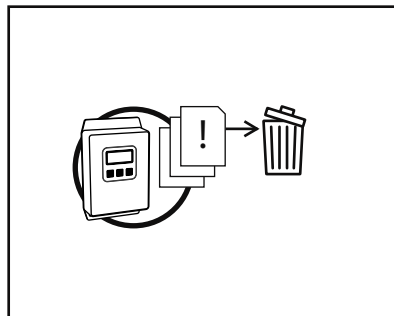

4.4.4 Delete Stored Error Codes

Stored error messages can only be deleted after all error messages have been viewed.

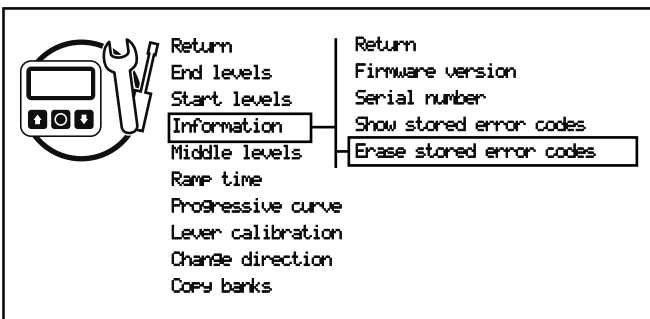

"Erase stored error codes" is a submenu to "Information" in the main menu and is used to delete stored error codes. See also chapter 11.6 Erase Stored Error Codes, page 94.

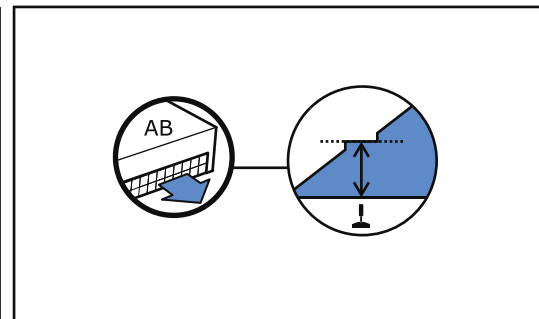

4.5 Middle Levels

The middle level is the signal level sent to an actuator when the lever controlling the actuator is in its middle position.

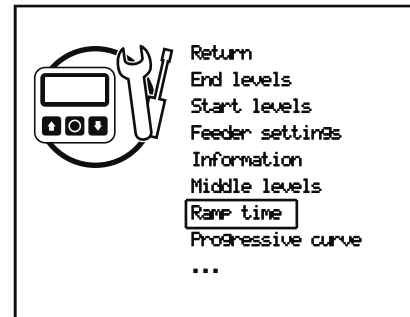
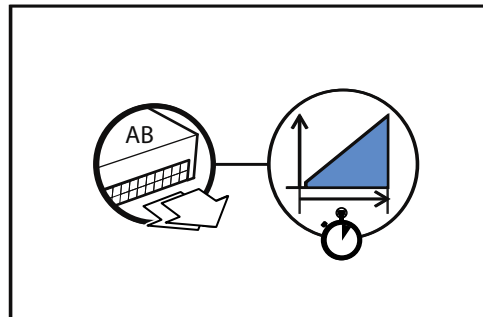
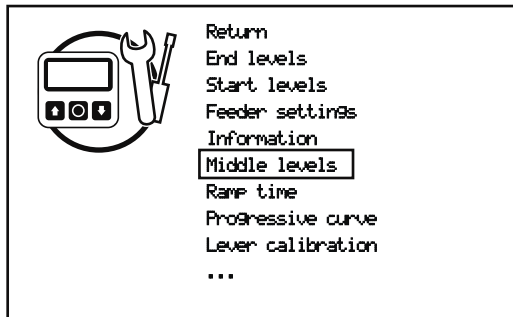

This option is only available if you have at least one output set as the actuator. "Middle levels" is found in the main menu. See also chapter 8.6 Middle Levels, page 69.

4.6 Ramp Time

Ramp time is the time it takes for the output signal to go from the start level to the end level when the lever is moved from the middle position to the end position.

"Ramp time" is found in the main menu. See also chapter 9.4 Ramp Time, page 78.

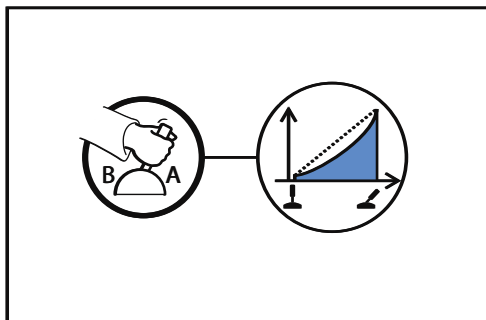

4.7 Progressive Curve

Progressive curve controls the relation between the lever movement and the speed of the hydraulic function.

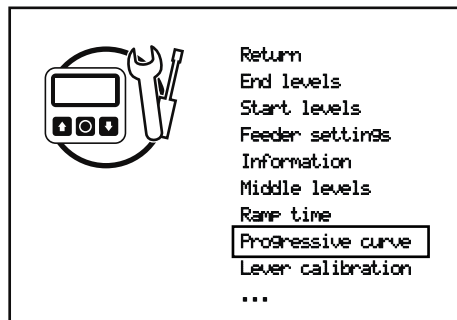

"Progressive curve" is found in the main menu. See also chapter 9.3 Progressive Curve, page 77.

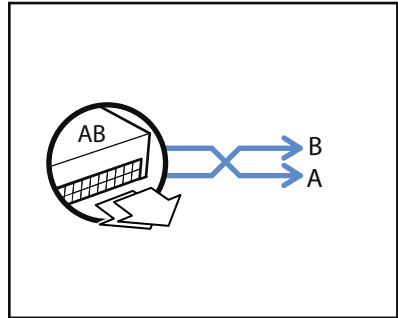
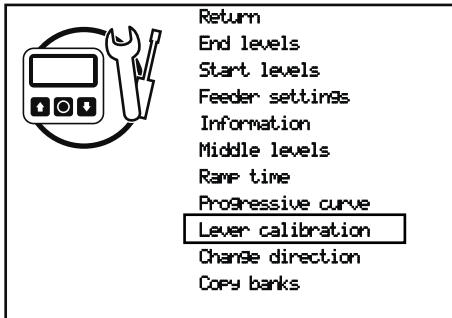
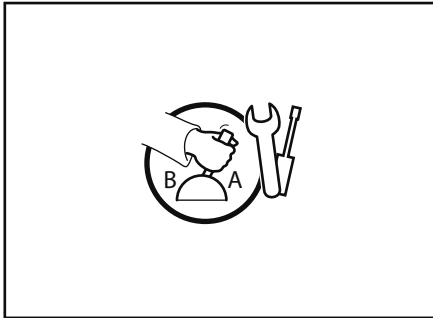

4.8 Lever Calibration

If a new lever is connected to the system, the lever should be recalibrated. Or if the first calibration was not successful.

"Lever calibration" is found in the main menu. See also chapter 9.1 *Lever Calibration*, page 74.

4.9 Change Direction

If required, the signals from a double-acting output can be reversed so that the valve is controlled in the opposite direction.

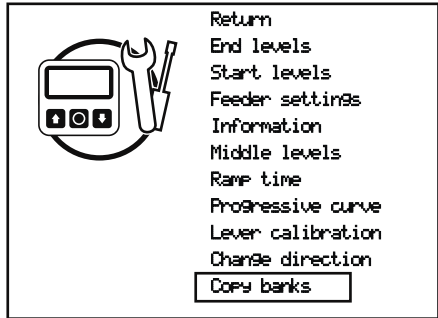
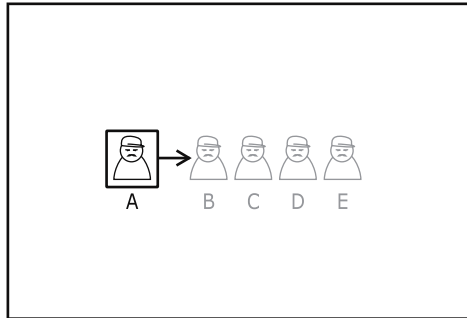
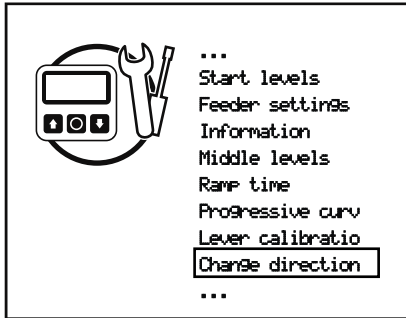

"Change direction" is found in the main menu. See also chapter 9.6 *Change Direction*, page 82.

4.10 Copy Banks

Once you have made settings to a data bank, it is possible to copy these to one of the other data banks.

"Copy banks" is found in the main menu. See also chapter 10.3 *Copy Banks*, page 88.

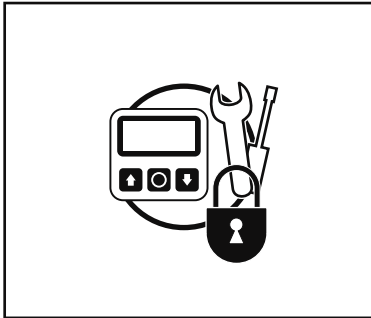

4.11 Enter Code

It is possible to lock certain menus in the main menu to prevent accidental settings changes.

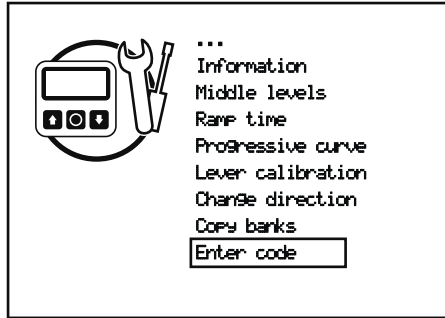

To lock these menus, select "*Enter code*" in the main menu. See also chapter 9.9 *Enter Code*, page 84.

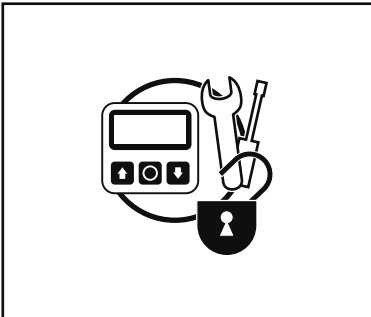

4.12 Unlock Menu

When the menus are locked, "*Unlock menu*" is shown in the main menu (instead of "*Enter code*"). Locked menus are unlocked with the help of the code.

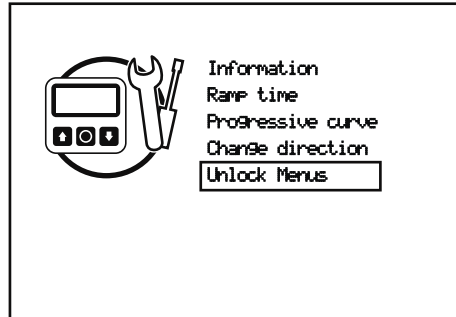

"*Unlock menu*" is found in the main menu and is used to unlock the menus. See also chapter 9.10 *Unlock Menu*, page 85.



5. Master Mode Menu Summary

What do you do in the Master Mode menu?

The Master Mode menu is used to change settings and adapt the system to your machine. This menu is intended mainly for installation technicians or advanced users.

Instructions:

Read and follow along with the master mode menu using your GP Controller (GPC).

Press the following combination to access the master mode menu:



Tip!

Note that the sub-menus in the master mode menu have the same order in this chapter as in your GPC.

Chapter:

Page:

5.1 Logic.....	38
5.1.1 In-test	38
5.1.2 Functions.....	38
5.1.3 Outputs.....	39
5.1.4 Double push.....	39
5.2 Output types.....	40
5.3 Rippel amplitude.....	40
5.4 Lever Calibration.....	40
5.5 Hysteresis.....	41
5.6 Erase EEPROM.....	41
5.7 Buzzer.....	41

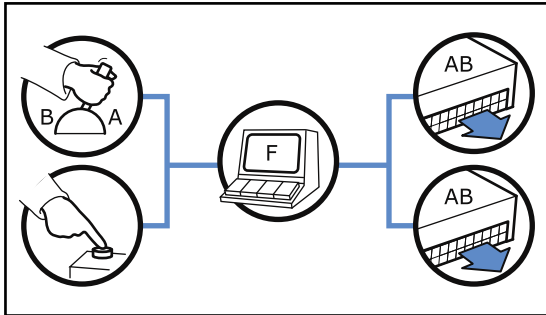

5.1 Logic

A GPC is equipped with 12 programmable functions. A function links the input signals with the outputs. Programming is used to give the exact desired results for your machine. For example, a combination of input signals (as shown in the figure above) can control several outputs. For more information, see chapter 7. *Logic Programming*.

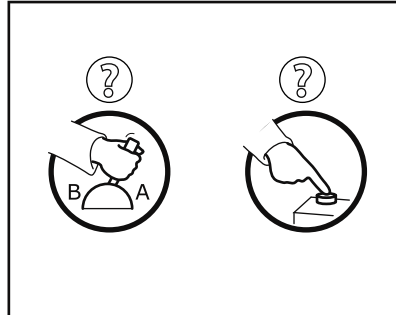

5.1.1 In-test

Using *In-test* you can test different input signals to discover whether they are connected and what they are called.

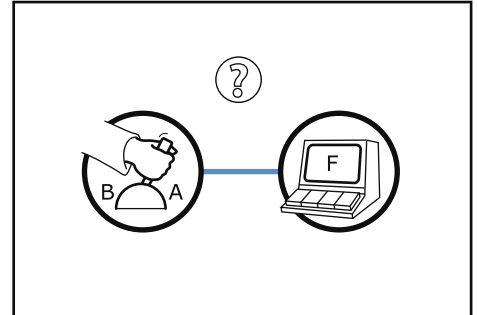

Using *In-test* you can also see whether the input signals are connected to a function.

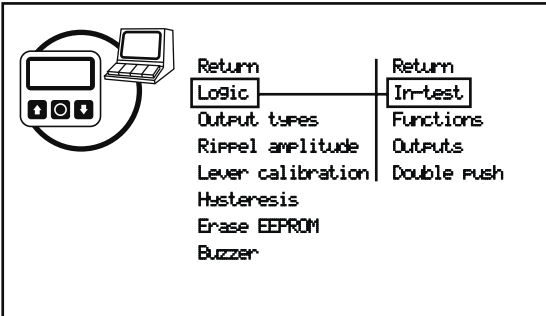

"*In-test*" is found under "*Logic*" on the master mode menu. To test input signals see chapter 7.7 *In-test*, page 50.

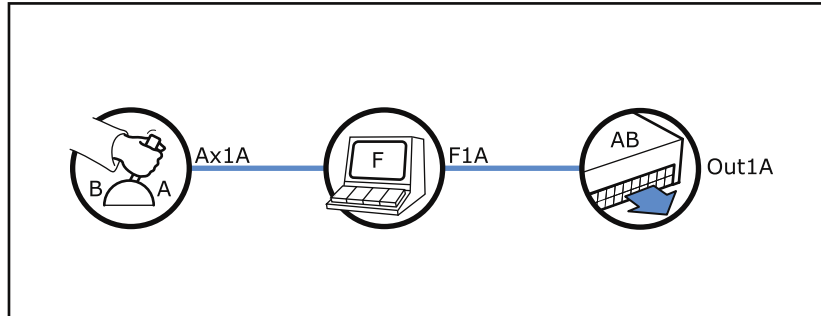

5.1.2 Functions

Functions determine "what should control what". For example, perhaps Ax1A should control Out1A with the help of F1.

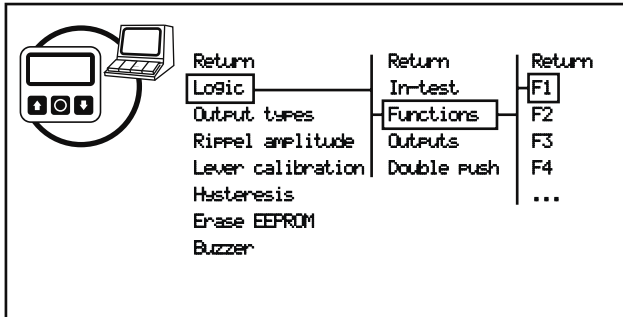

To read more about how inputs are connected to functions see chapter 7.2 *Programing functions*, page 51.

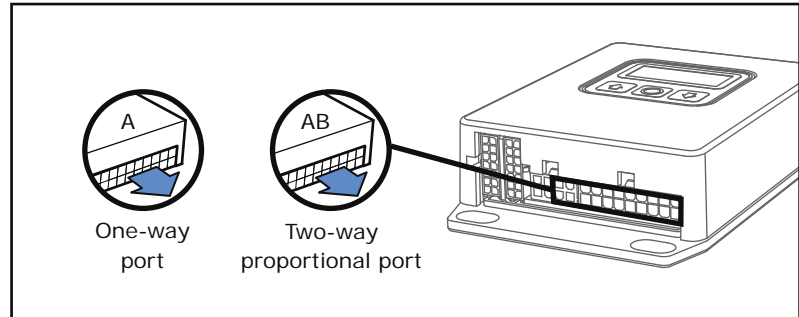

5.1.3 Outputs

The outputs control the valves by regulating the amperage to the magnetic coils on the valves. The GPC has 9 outputs, of which 5 are two-way proportional outputs and 4 are one-way on/off outputs.

For more information about outputs see Appendix 1 page 96.

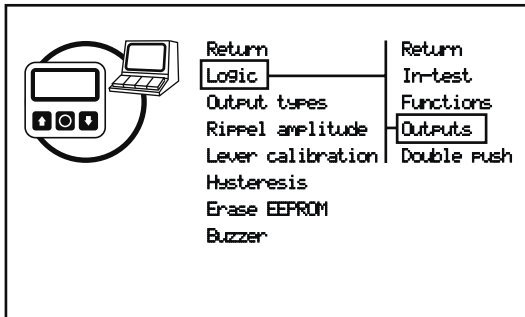

“Outputs” is a submenu to “Logic” in the Master Mode menu, see chapter 7. *Logic Programming*, page 49.

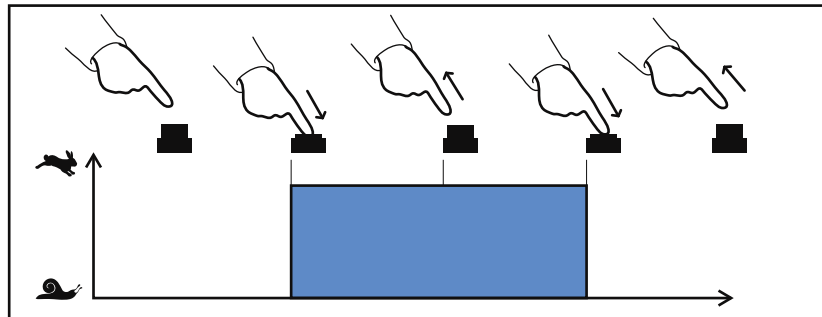

5.1.4 Double push

A button programmed with double push is activated with a single push and deactivated with an additional push.

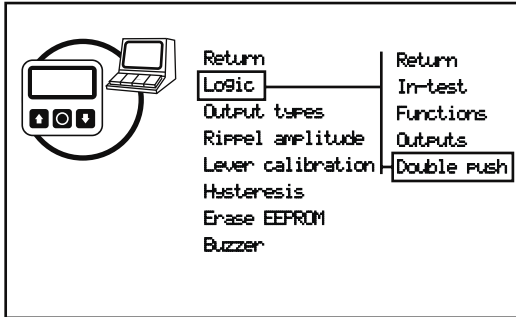

Activate "Double push" in the submenu to "Logic". See also chapter 7.4 *Double push*, page 59.

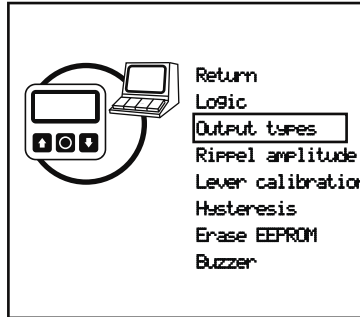

5.2 Output types

The valve type which each output controls is determined on the "Output types" menu. See also chapter 6.1 *Output types*, page 44.

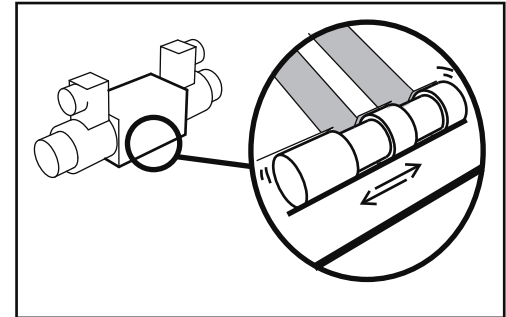

5.3 Rippel amplitude

Rippel is the variation in amperage that keeps the valve slide in vibration, which in turn means that it becomes more adaptive and can be controlled without jerking.

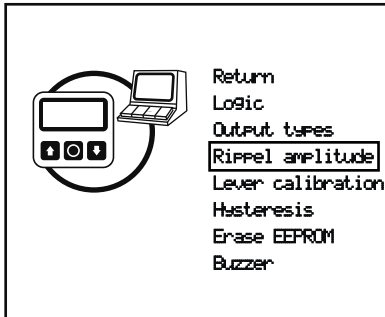

"Rippel amplitude" is found in the master mode menu. See also chapter 9.5 *Ripple Amplitude*, page 81.

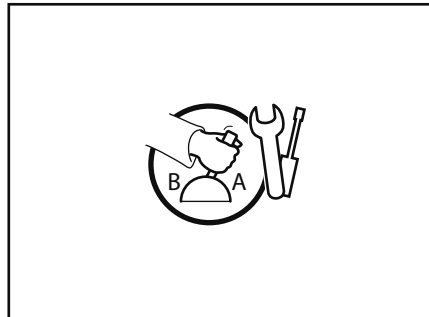

5.4 Lever Calibration

If a new lever is connected to the system, the lever should be calibrated.

The lever should be recalibrated if the initial calibration was not successful.

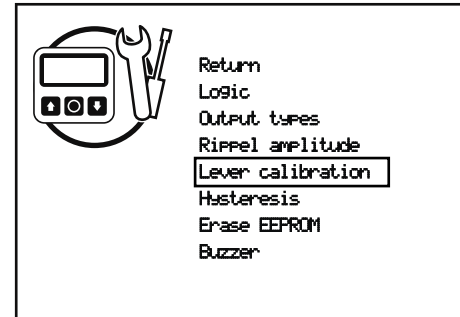

"Lever calibration" is found in the main menu. See also chapter 9.1 *Lever Calibration*, page 74.

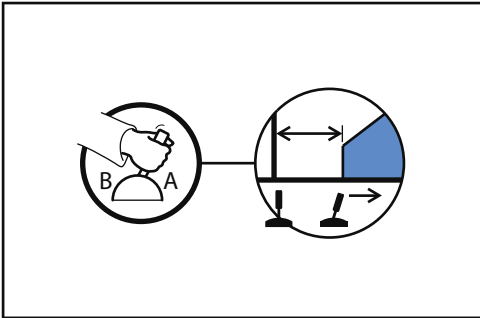

5.5 Hysteresis

Hysteresis determines how much play the lever has in the middle position.

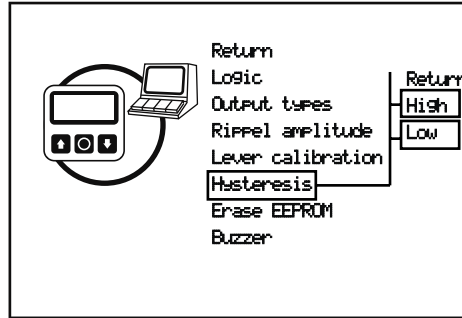

"Hysteresis" is found in the master mode menu. In the sub-menu choose the setting "High" or "Low". See also chapter 9.2 Hysteresis, page 76.

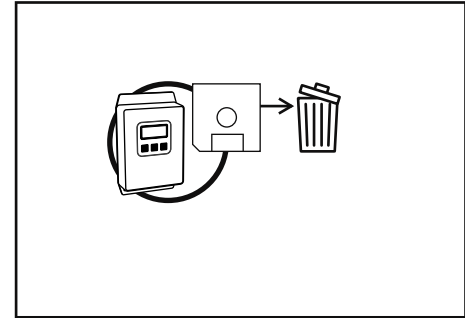

5.6 Erase EEPROM

WARNING! This option restores all settings to their default values. All logic settings are deleted.

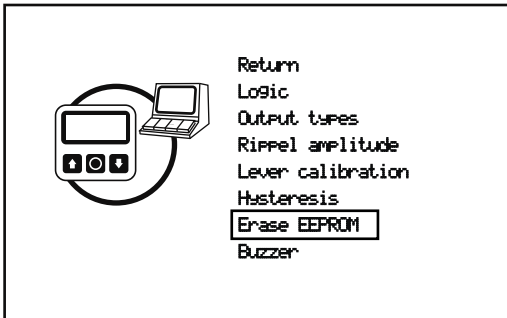

When the EEPROM-memory is erased the system restarts and the start up settings must be set up again. "Erase EEPROM" is found in the master mode menu. See also chapter 11.7 Erase EEPROM, page 95.

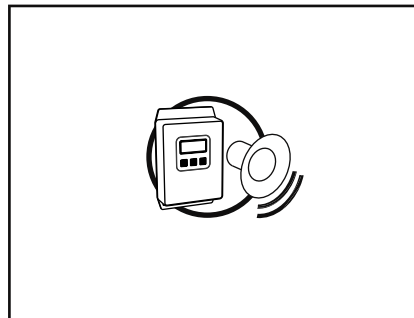

5.7 Buzzer

The GPC is equipped with a buzzer. The buzzer volume can be adjusted.

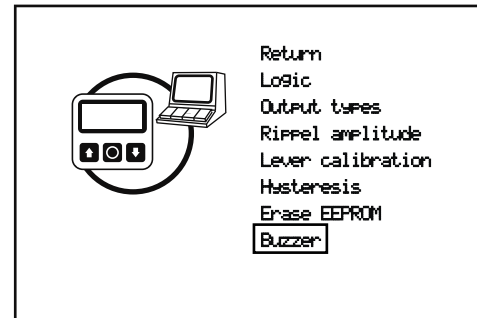

"Buzzer" is found in the master mode menu. To adjust the buzzer's sound level see chapter 9.8 Buzzer, page 83.



6. Output Types

What does Output Type mean?

To set the output type means that outputs are set so that they correspond to the valve they are connected to. The setting determines which type of signal is to be used to control the valve. Setting the correct output type is fundamental if the valves and system are to function correctly.



Tip!

It is important to first set the output type, as certain menu options only become active when an output type has been selected correctly.

Instructions:

1. Read about the different output types in section *6.1 Output types*.

2. Set the output type for all outputs:

If you have a control system for excavators, follow the corresponding setting instructions in Appendix 5 to Appendix 9. If you have another type of control system, you should follow the setting instructions in the system documentation.

3. Activate electrical current monitoring for the output.

4. Continue to chapter 7.

Chapter:

6.1 Output types	44
6.2 Feeder outputs	45
6.3 Current monitoring.....	47

Page:

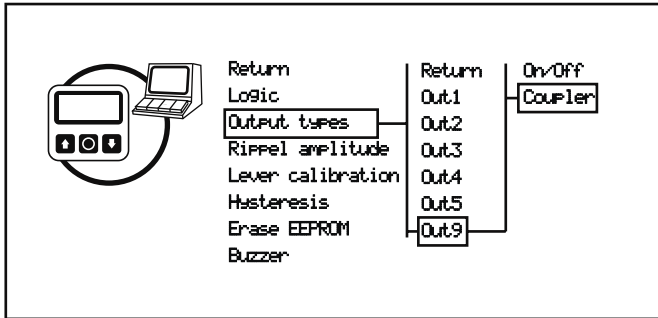

6.1 Output types

"Output types" is found in the master mode menu. Output type for corresponding output is selected via a submenu. Out9 can be set using two options: as "On/Off" or "Coupler".

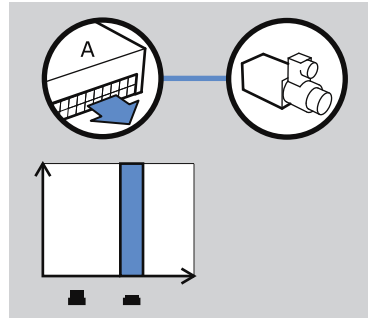

Out9 - "On/Off" is used to connect a single-acting valve controlled only as either open or closed. (Out6-Out8 are always setup in this way.)

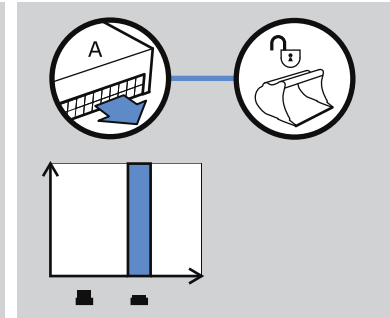

"Coupler" is used if Out9 is connected to a coupler, aka tool lock. This output type activates the extra safety functions needed to control the coupler.

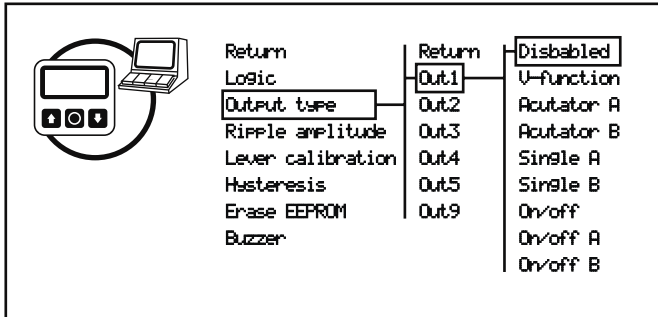

The Output type for Out1-Out3 can be set using nine options: "Disabled", "V-function", "Actuator A", "Actuator B", "Single A", "Single B", "On/Off", "On/Off A" and "On/Off B".

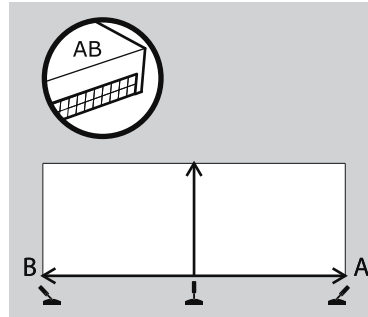

"Disabled" means that the output does not send a signal.

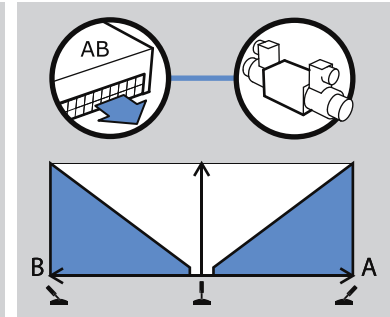

"V-function" is used for valves that need to be controlled proportionally and in two directions.

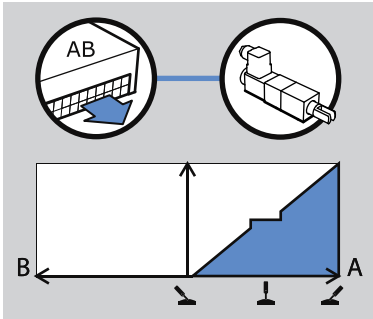

"Actuator A" is used when an actuator is to be controlled proportionally and in two directions. As an actuator only needs one output, the B-output is not used.

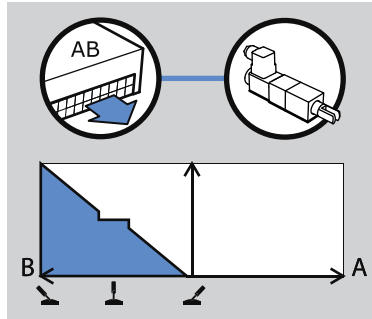

"Actuator B" works exactly as "Actuator A" however the signal is sent on the B-output instead of the A-output.

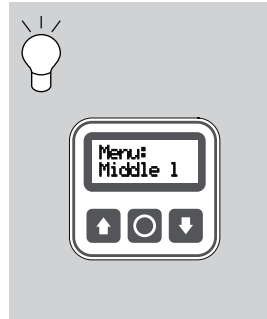

When actuator is selected as the output type an additional option "Middle levels" is added to the main menu.

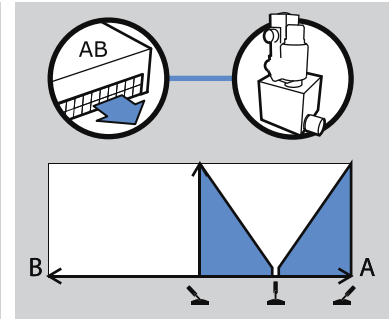

Output type "Single A" only sends a signal on the A-output even if the axis is drawn to B. This type is used, among others, with wheel control valves.

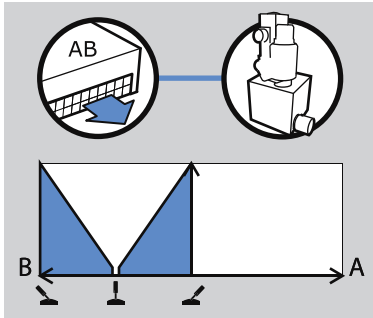

Output type "Single B" works similarly to "Single A" but uses only the B-output.

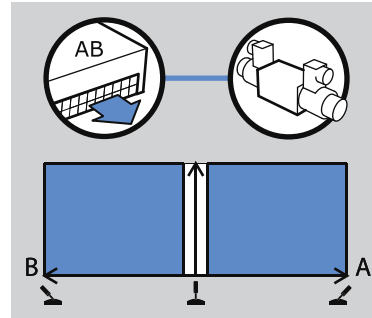

Output type "On/Off" is used for valves that need to be controlled in two directions and in two positions, either open or closed.

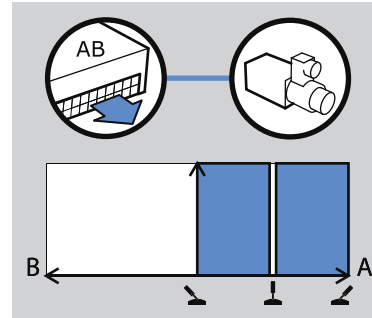

Output type "On/Off A" is used for valves that need to be controlled in one direction, either open or closed. "On/Off B" works similarly, but uses the B-output.

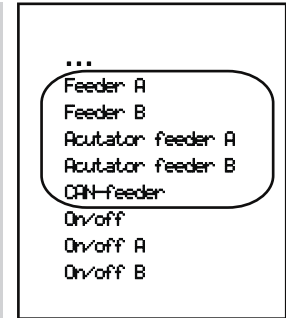

6.2 Feeder outputs

Outputs 4-5 have five additional output control options to choose from.

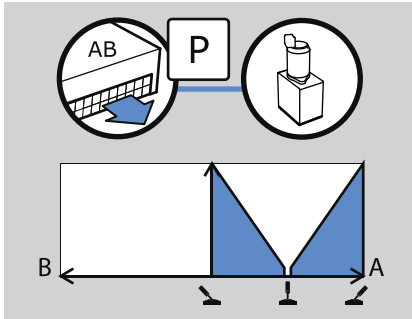

"Feeder A" is selected if a proportional shuttle valve is to be connected to the output to control the feeder. "Feeder B" works similarly, but uses the B-output.

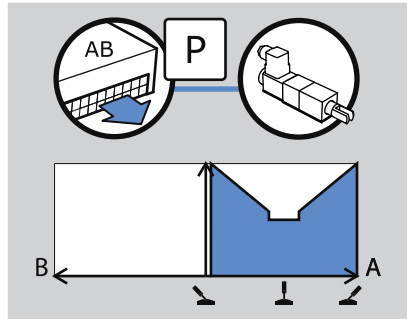

"Actuator feeder A" is selected if the output is linked to an actuator that should control the feeder. "Actuator Feeder B" works similarly, but uses the B-output.

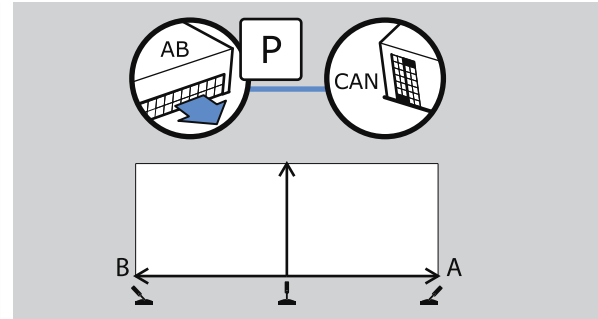

The option "CAN-feeder" is used if a CAN-splitter should control the feeder. NOTE! The output will not send a signal on either the A- or the B-output. The signal is sent to the CAN-bus, see Appendix 1.



When an output is selected to be a feeder, the option "Feeder settings" is added to the main menu.

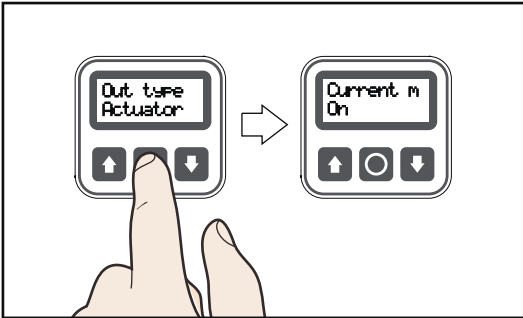

6.3 Current monitoring

When you have chosen output type (for Out1-5) you may also select whether the output should monitor the current. (Out6-Out9 are always current monitored.)

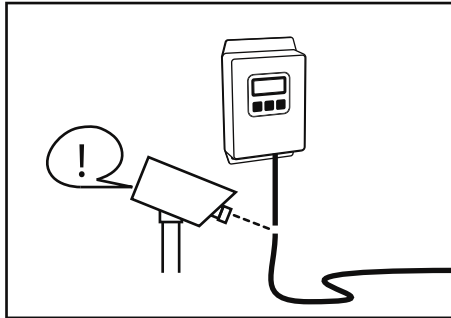

Current monitoring means that open circuit and short-circuiting monitoring is performed on the output.

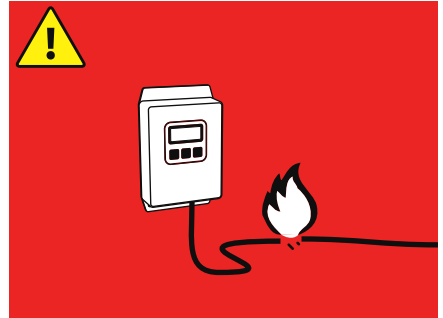

WARNING Switching off current monitoring may increase the risk of damage to the equipment or person injury in the case of short-circuiting.

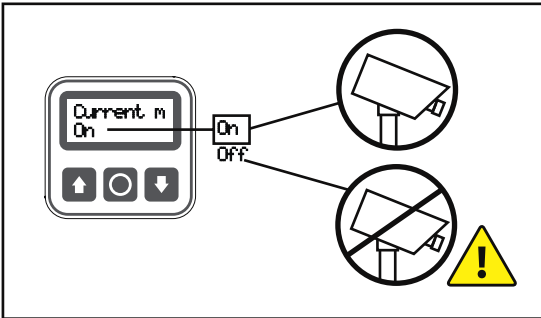

Choose "On" or "Off" for current monitoring.



7. Logic Programming

What is a function?

The GP Controller (GPC) is equipped with 12 programmable functions. A function links the input signals with the outputs:



For example, you can program a function so that a combination of input signals control several outputs.

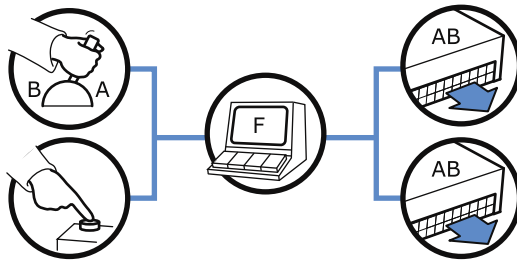

Tip!

An analog axis must always go through a function to control an output. However, a digital input signal may be programmed to directly control a single-acting output.

Instructions:

1. Check all connected input signals with *In-test*.
2. Control system for excavators, program functions according to one of the setting instructions in Appendices 5-9. Other control systems, follow the setting instructions accompanying the system documentation.
3. Optional, activate double push for buttons (digital input signals or DIN).
4. Continue to the next chapter.

Chapter:

Page:

7.1 In-test.....	50
7.2 Programing functions.....	51
7.3 To program a feeder	58
7.4 Double push.....	59
7.5 Import functions	60
7.6 Control a function with a function.....	61



Tip!

The GPC can program functions automatically the first time it is started, but you usually need to program some functions yourself.

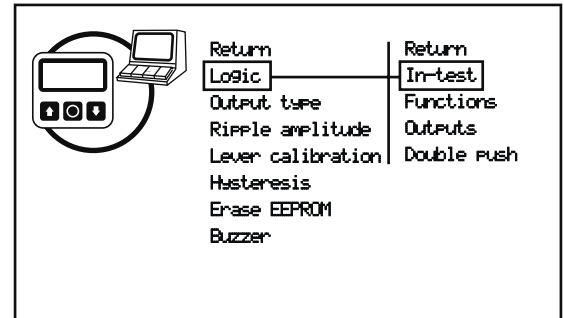
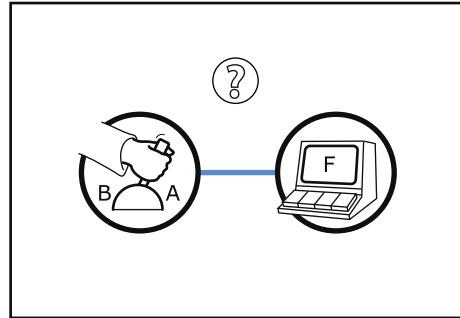
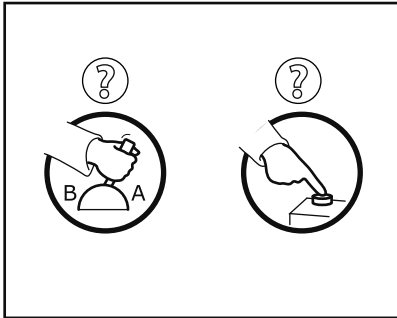

7.1 In-test

Using "In-test" you can test different input signals to discover whether they are connected and what they are called.

In addition, "In-test" will also show whether the input signals are connected to a function.

1. To test the input signals, select "In-test" in the menu "Logic" in the master mode menu.

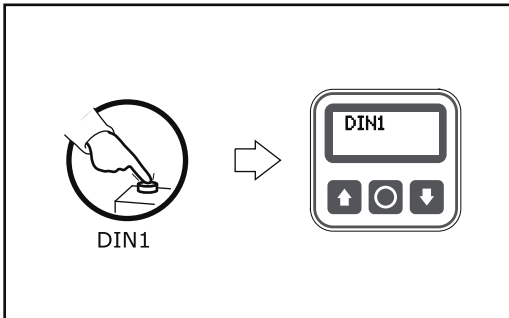

2. Activate an input signal. The GPC indicates that the input signal is working by displaying its name.

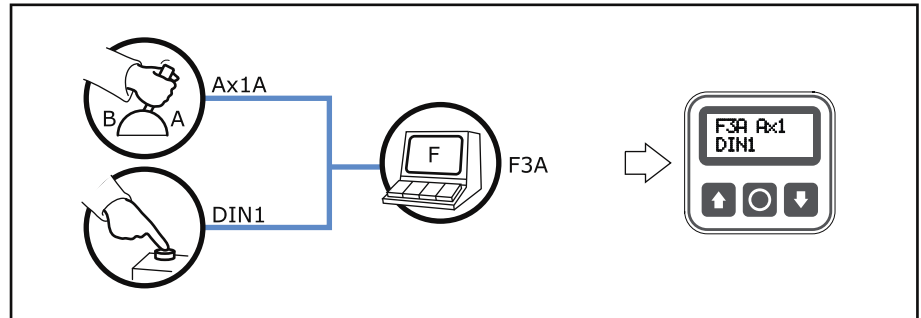

3. If the input signals have been programmed to control a function, then this is shown on the display. (In the example above the display shows that DIN1 and Ax1 are programmed to control function 3.)

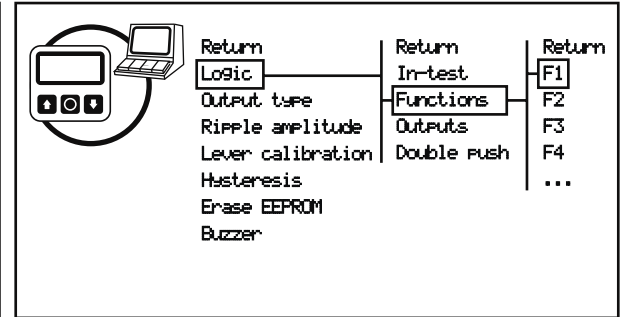
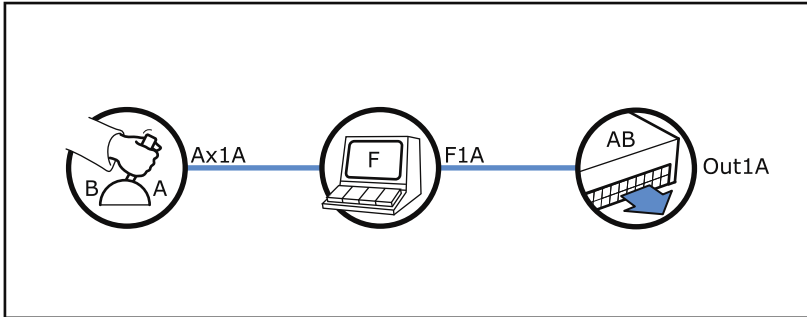

7.2 Programming functions

Example 1. Ax1 controls Out1 via F1.

- Pull Ax1 towards A to send the signal on Out1A.
- Pull Ax1 towards B to send the signal on Out1B.

1. To program a function, select "F1" in the sub-menu "Functions", under "Logic" in the master mode menu.

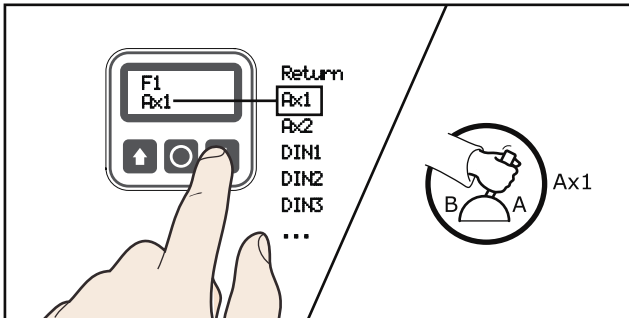

2. The display now shows a list of the input signals which control functions. Scroll with the arrow keys to "Ax1". You can also select the input signal by pulling Ax1.

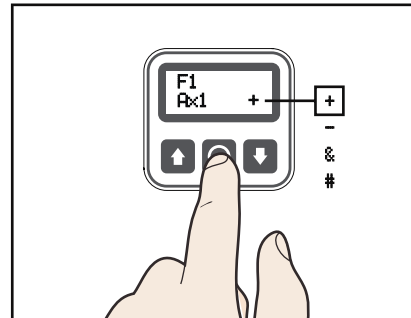

3. Press the middle button to select a function symbol. An input signal with no designated function sign will not be included in the function.

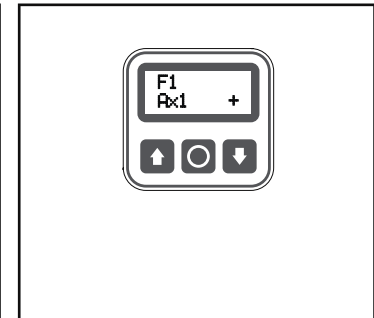

4. Selecting the plus sign (+) means that Ax1 controls F1.



+ - & #

There are four function symbols that can be used when programming a function, these are:

- + Input signal steers the function.
- Input signal steers the function, but in the opposite direction.
- & The function forwards a signal only if the an input signal is activated.
- # The function does NOT forward a signal if an input signal i activated.

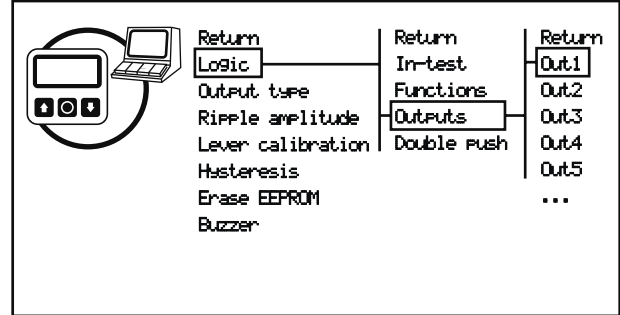

5. To program F1 to control Out1, select "Out1" in the sub-menu "Outputs" under "Logic" in the master mode menu.

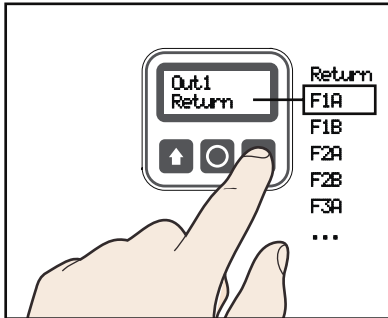

6. Scroll to "F1A" using the arrow keys.

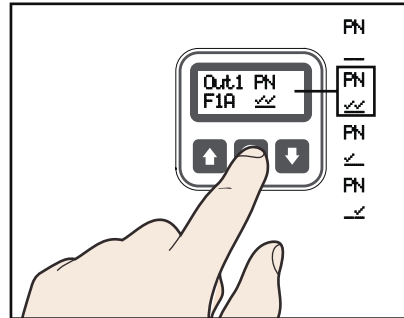

7. Select double-checkmarks for F1A using the middle button.

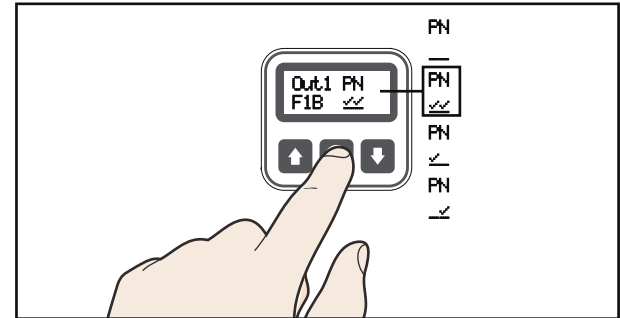

8. Now scroll to F1B and select double-checkmarks. F1 is now connected to Out1 in both directions, A and B. The function is now programmed.

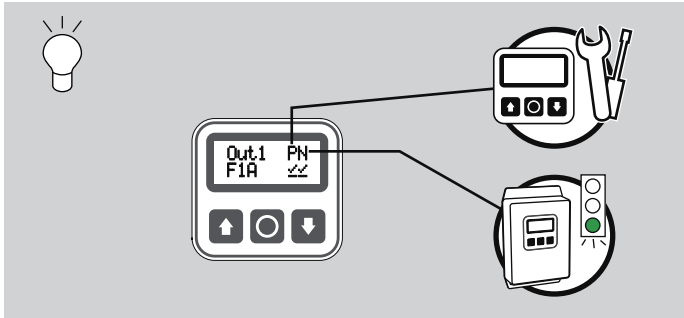

A double checkmark indicates that the output can control a valve in both the operating mode and when settings are made in the main menu. Operating mode is also known as normal mode, (N=Normal mode) and the main menu settings are known as programming mode (P=Programming mode).



If it is desired that the system act differently depending on whether you are in the programming (P) or operating (N) mode, then use only one checkmark under the respective alternative. In the example above, the function only controls the output in the operating (N) mode, but NOT the programming (P) mode. This is used for example in the track steering configuration.

Note! If you are unsure, always use double-checkmarks!

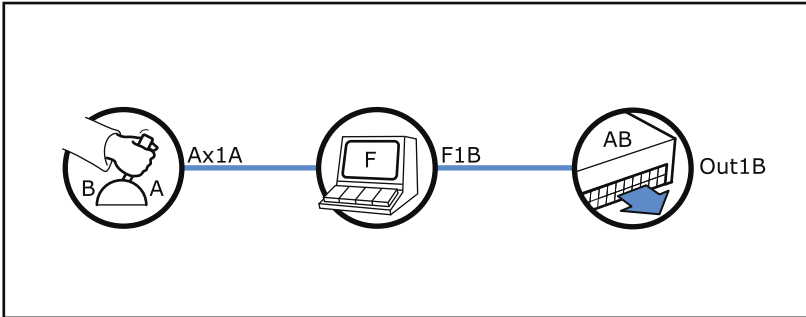

Example 2. Ax1 controls Out1 but in the opposite direction.

- Pull Ax1 towards A to send the signal on Out1B.
- Pull Ax1 towards B to send the signal on Out1A.

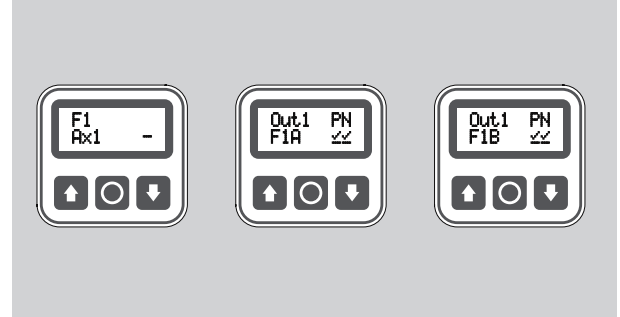

1. Start the Master Mode menu and select "F1" in the menu "Logic", "Functions". Select a minus sign next to Ax1. Now choose "Out1" under the menu "Logic", "Outputs" and select checkmarks for both F1A and F1B.

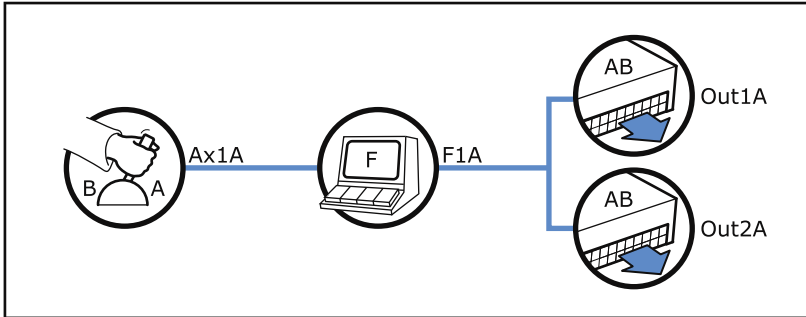

Example 3. Ax1 controls both Out1 and Out2.

- Pull Ax1 towards A to send the signal on Out1A and Out2A (see above).
- Pull Ax1 towards B to send the signal on Out1B and Out2B.

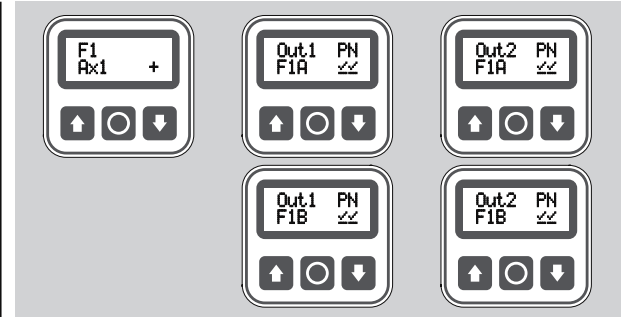

1. Start the Master Mode menu and select "F1" in the menu "Logic", "Functions". Select a plus sign next to Ax1. Select checkmarks for both F1A and F1B under both Out1 and Out2.

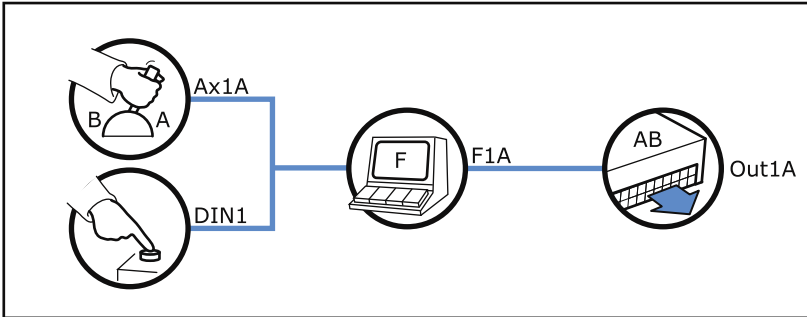

Example 4. Ax1 and DIN1 control Out1.

- Pull Ax1 towards A to send the signal on Out1A.
- Pull Ax1 towards B to send the signal on Out1B.

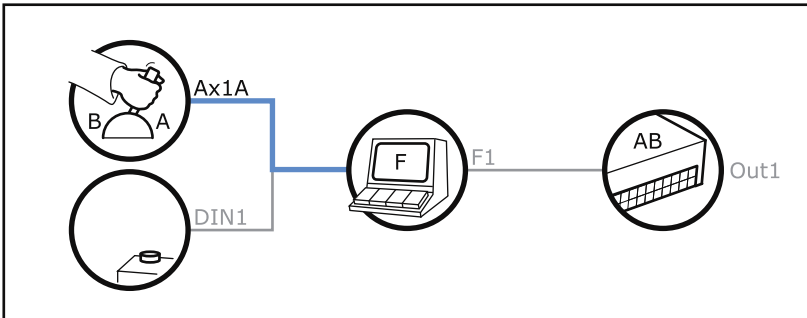

- DIN1 must be pressed in for the signal to be sent to the output.

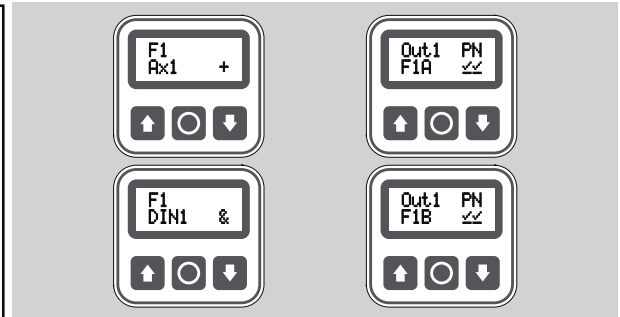

1. Start the Master Mode menu and select "F1" in the menu "Logic", "Functions". Select a "+" next to Ax1 and an "&" after DIN1. In the sub-menu "Out1" under "Logic", "Outputs" select checkmarks for both F1A and F1B.

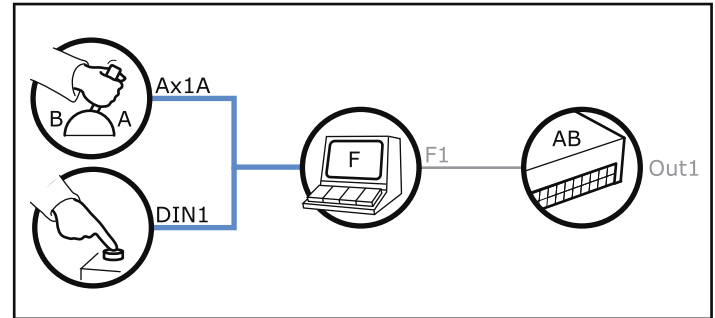
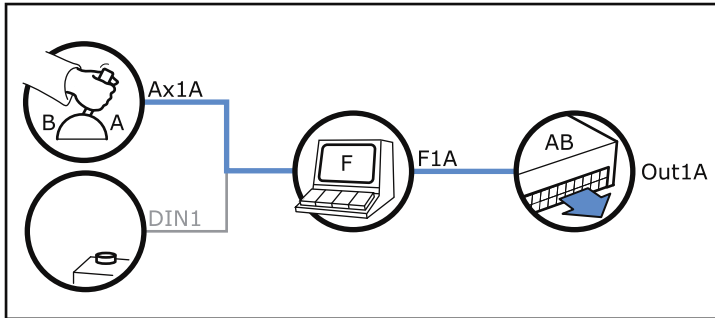

Example 5. Ax1 and DIN1 control Out1.

- Pull Ax1 towards A to send the signal on Out1A.
- Pull Ax1 towards B to send the signal on Out1B.

- If DIN1 is activated the signal will not be sent to the output.

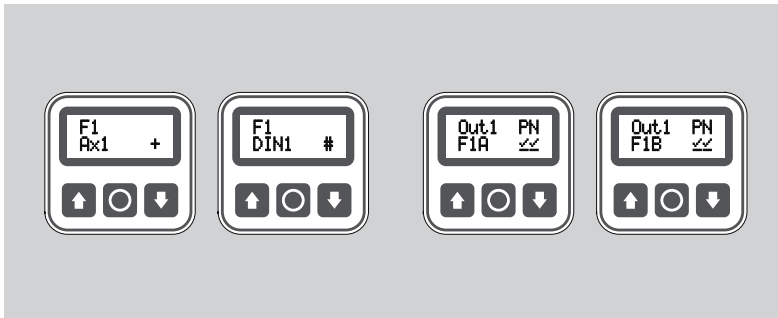

1. Start the Master Mode menu and select "F1" in the menu "Logic", "Functions". Select a "+" next to Ax1 and a "#" next to DIN1. In the sub-menu "Out1" under "Logic", "Outputs" select checkmarks for both F1A and F1B.

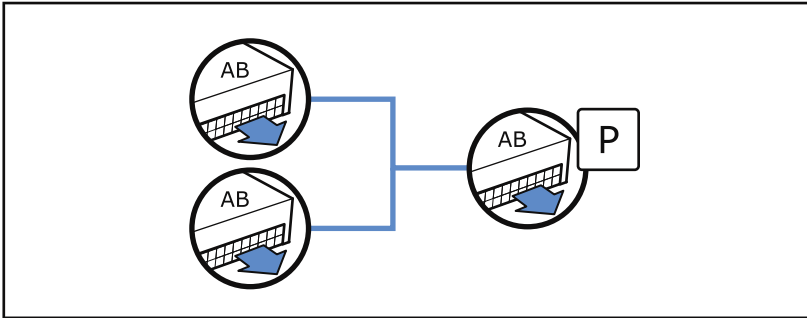

7.3 To program a feeder

A feeder output is not controlled by a function, but by other outputs. The feeder output takes the outputs' signals into consideration and combines them into one signal that controls the feeder.

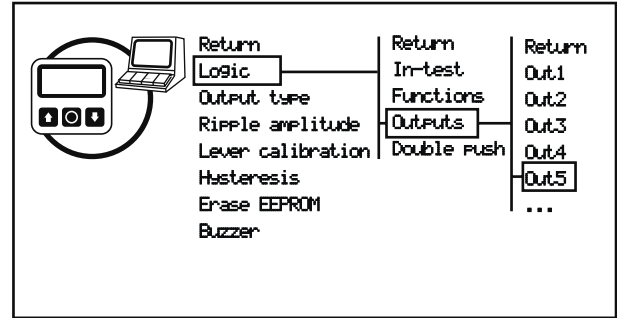

1. To program a feeder, select "Out5" (feeder output) in the submenu "Outputs" under "Logic" in the master mode menu. NOTE! Before beginning, the correct output type must be set for Out5 (see chapter 4. *Main Menu Summary*).

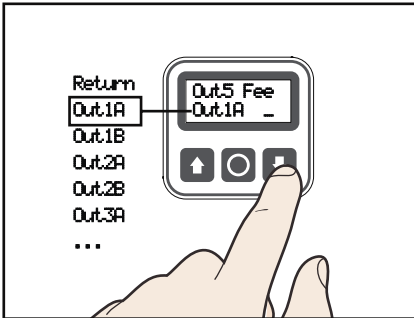

2. Scroll the outputs using the arrow keys.

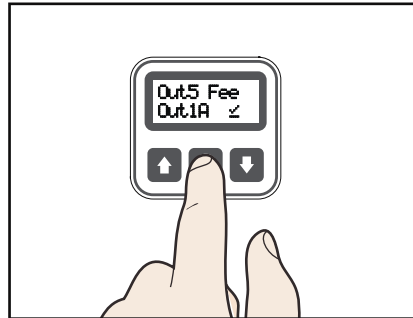

3. Use the middle button to select a checkmark by the outputs that will control the feeder (see Appendixes 5-9 for a setting example).

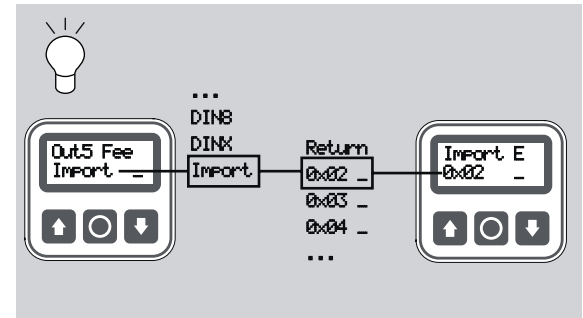

At the bottom of the check menu you will find "Import". Use this choice to import values from another feeder. NOTE! The units you wish to import must have an output assigned as CAN-Feeder. See chapter 6.1 *Output types* page 44 for further information on how to setup outputs to CAN-Feeder.

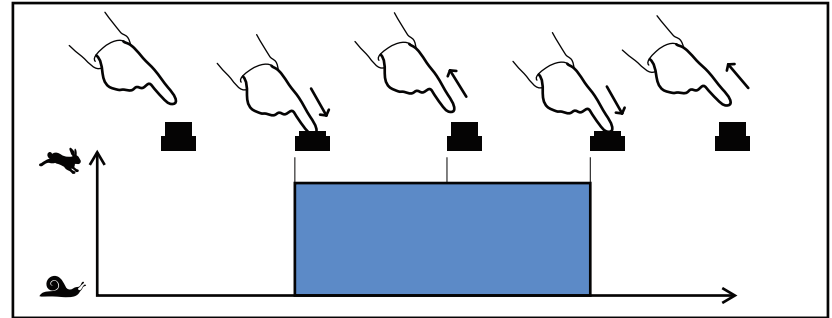
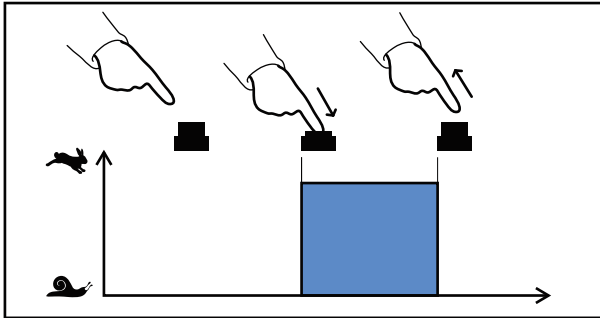

7.4 Double push

Normally a button is ON when pressed down and OFF when released.

A button programmed with double push is activated with a single push and deactivated with an additional push.

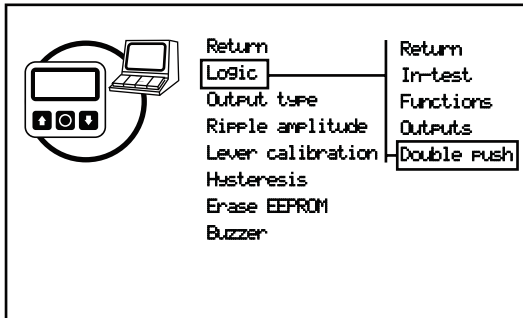

1. To program a double push button, select "Double push" under "Logic" in the master mode menu.

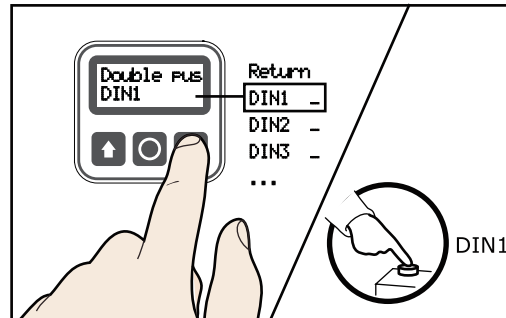

2. Scroll and select the button to be set as double push.

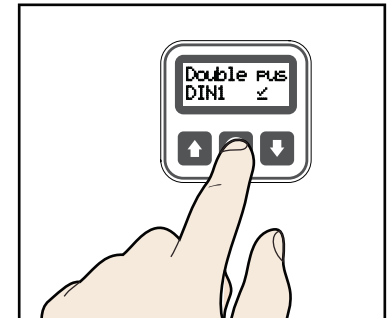

3. Activate double push by selecting a checkmark.

Note: The button can also be selected simply by pressing it.

7.5 Import functions

Some control systems are more complicated and require several interconnected GP Controllers in order to control all the desired hydraulic functions. Using the option "Import" a function can be controlled by a function from another unit via the CAN-bus. This can be useful if you want to control an output with the help of input signals linked to the other unit.

Tip!

If several units are connected via the CAN-bus, in some menu options you will first need to select for which unit you wish to make the settings. Selections in the following menus will only affect the unit you have selected.

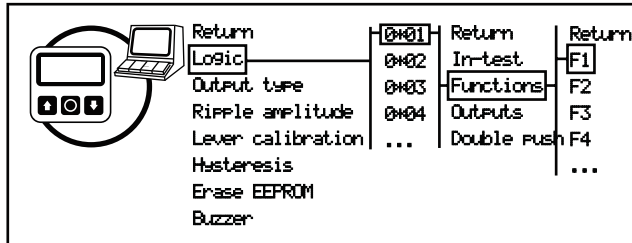
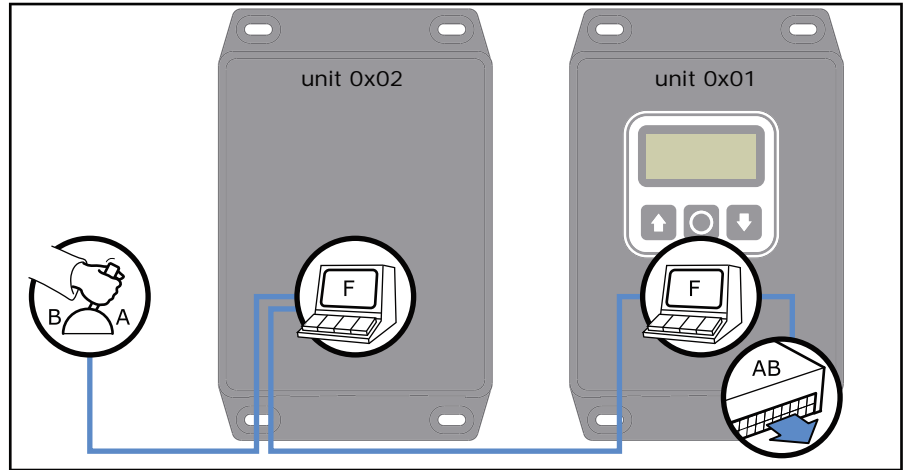

1. To import a function, go to "Logic" in the master mode menu. Select which unit you want to program, e.g. unit "0x01". In the "Functions" sub-menu, select a unused function to program, e.g. F1.

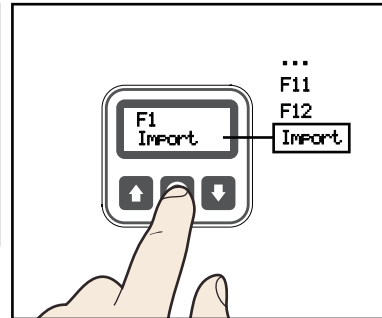

2. Scroll the list and select "Import".

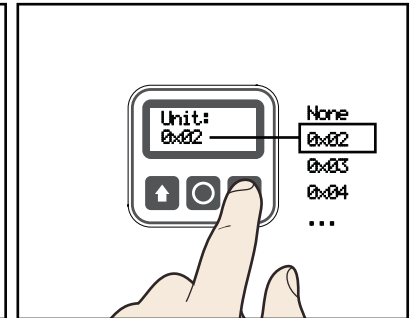

3. Scroll and select a unit from which to retrieve a function, e.g. "0x02" (unit 2).

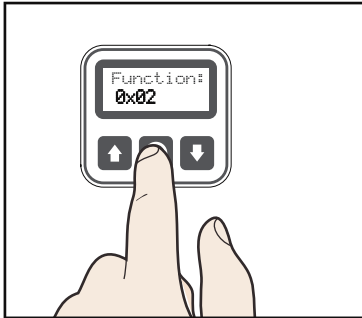

4. Press the middle button to continue.

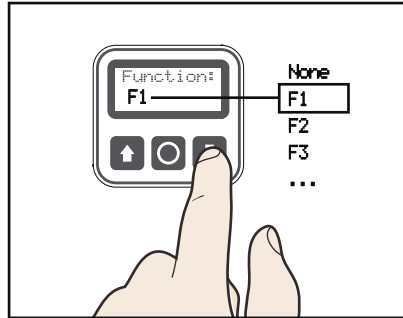

5. Scroll Unit 2 and select a function, e.g. "F1".

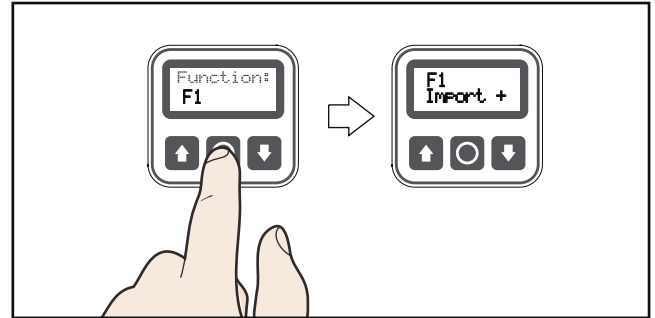

6. Press the middle button to continue. Function F1 in Unit 2 now controls F1 in Unit 1. Note that the imported function always receives the "+" function symbol.

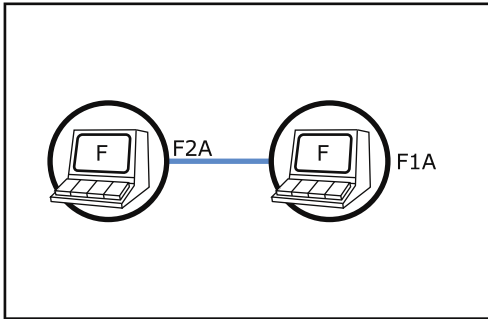

7.6 Control a function with a function
It is possible to control a function with the help of another function in the same unit. In this example F1 is controlled by F2.

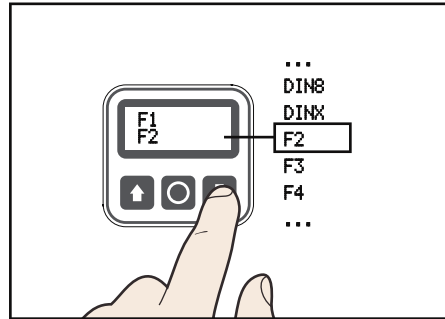

1. Select "F1" in the submenu "Functions" under "Logic" in the master mode menu. Scroll and select "F2".

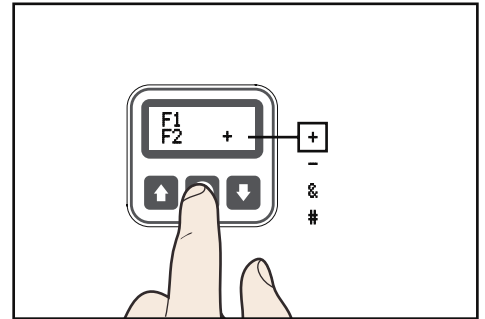

2. Scroll and select a function symbol.
(see Function Signs Guide on page 52)

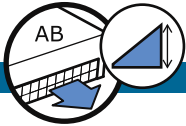

8. Adjustment Instructions

General:

Once the functions have been programmed it is time to adjust the signals for all outputs.

Electrical current levels determine the output signal strength in different lever positions. For example, the end level regulates how much the valve will open when a lever is in its maximum position.

The system should now be ready to use.

The remainder of this manual, chapters 9-11, describe how the system can be further adapted, but is not necessary for all users or machines.

Instructions:

If the system has a feeder, do the following adjustments:

1. Set the middle level (if the feeder is an actuator).
2. Set the feeder's start level.
3. Set the feeder's end levels.

The feeder has an end level for each output it is controlled by; the end level should also be set for both directions.

4. Set the feeder's fixed levels.
5. Set the feeder's max level.

Now continue to set the output levels that control the external valves:

6. Set the middle level (if the valve is an actuator).
 7. Set the start level in both directions.
 8. Set the end level both directions.
9. Repeat instructions 6-8 for each output.

Chapter:

Page:

8.1 Set the Feeder's Middle Level.....	64
8.2 Feeder's Start level	65
8.3 Feeder's End Levels	66
8.4 Feeder's Fixed Levels.....	67
8.5 Feeder's Max Level	68
8.6 Middle Levels.....	69
8.7 Start Levels.....	71
8.8 End Levels	72

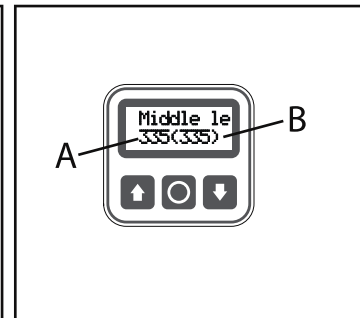
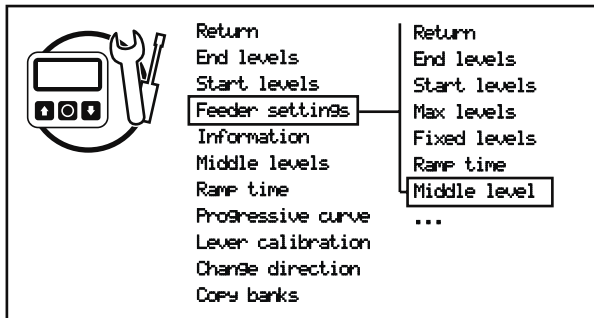
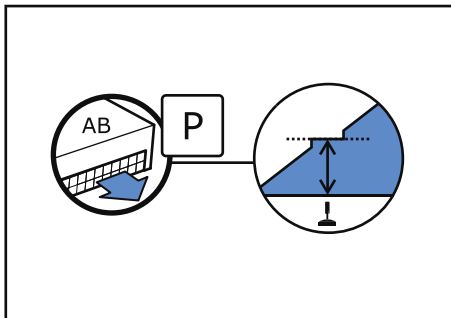

8.1 Set the Feeder's Middle Level

The middle level is the signal level sent from the feeder output to the feeder's actuator when all analog axis are in their middle positions.

1. To set the middle level for the feeder output, select "Middle level" under "Feeder settings".

Values for the middle level are displayed as:

A shows the new value
B shows the previous value

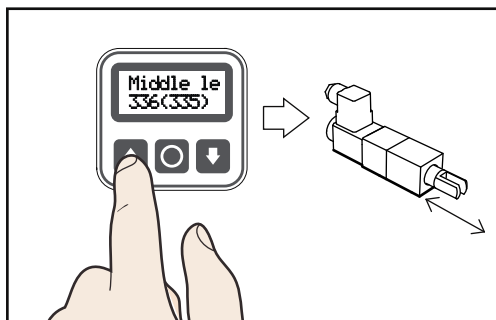

2. It is now possible to control the actuator backwards and forwards using the arrow keys.

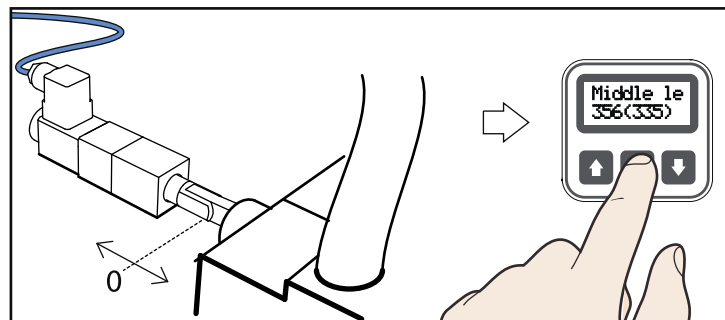

3. Adjust the position of the actuator so that the valve slide in the machine's valve block is in the neutral position. Save the value using the middle button.

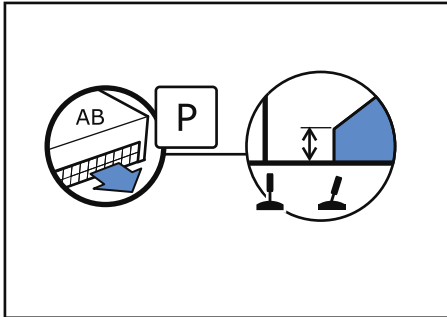

8.2 Feeder's Start level

The feeder's start level is the signal level sent to the feeder when a lever is pulled to its start position.

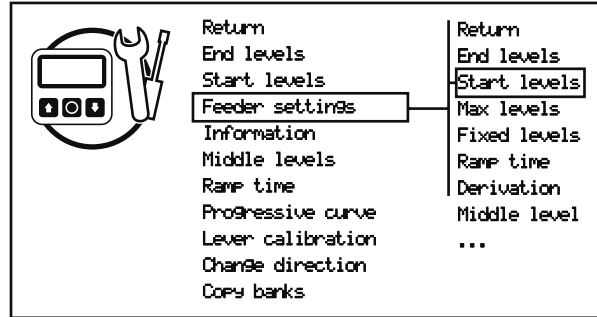

1. To set the start level for the feeder output, select "Start levels" under "Feeder settings".

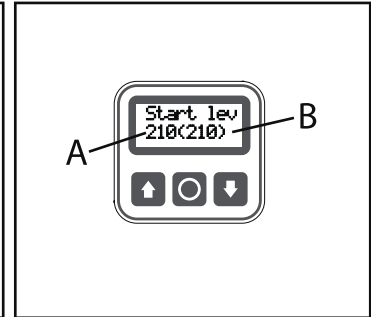

Values for the start level are displayed as:

A shows the new value
B shows the previous value

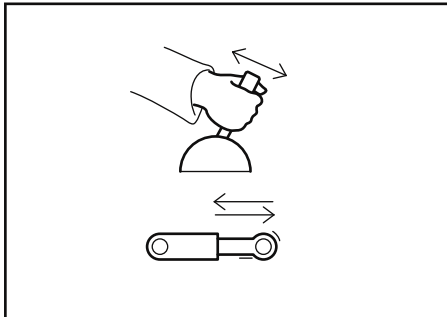

2. To set a start level for a hydraulic function, pull the lever (analog axis) that controls it. The chosen hydraulic function can now be controlled back and forth.

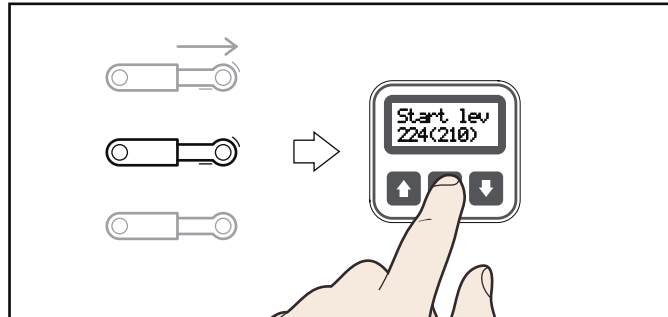

3. Hold the lever in the desired position where the feeder is just on the verge of supplying oil and the hydraulic cylinder is stationary but on the verge of moving. Save the value using the middle button.

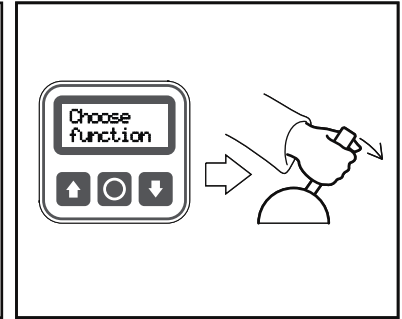
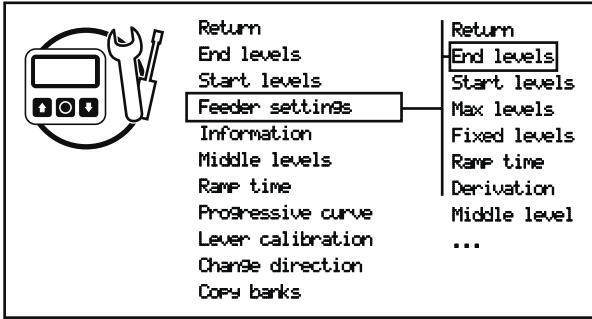
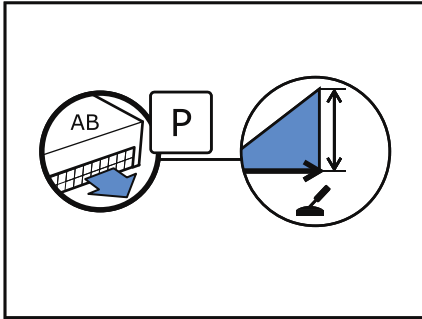

8.3 Feeder's End Levels

The feeder's end level is the signal level sent from the feeder output to the feeder when the lever is in its end position.

1. To set or adjust an end level, select "End levels" under "Feeder settings".

2. Pull the lever that is programmed to control the output. If the lever is linked to several outputs, you must choose one with the arrow keys.

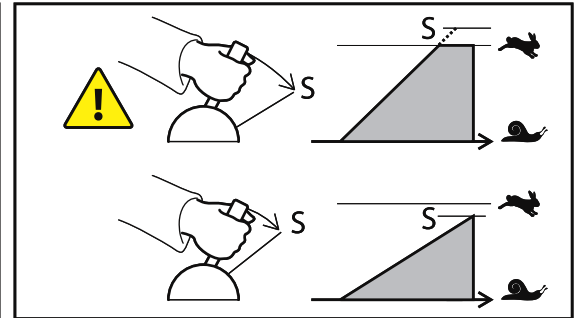
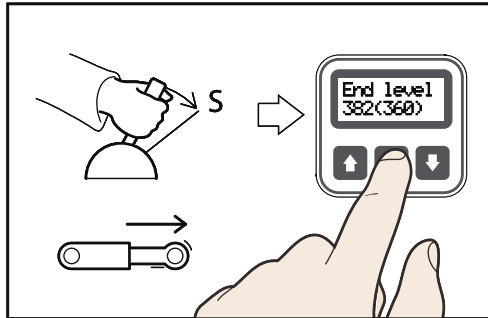
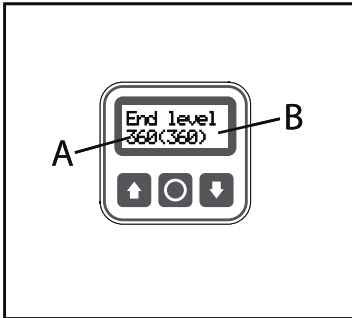

Values for the end level are displayed as:

A shows the new value
B shows the previous value

3. To save the end level value, hold the lever in the position that provides a desirable highest speed, while at the same time pressing the middle button to save this value.

Note: Never increase the signals more than you can observe the speed increasing over the entire lever movement!

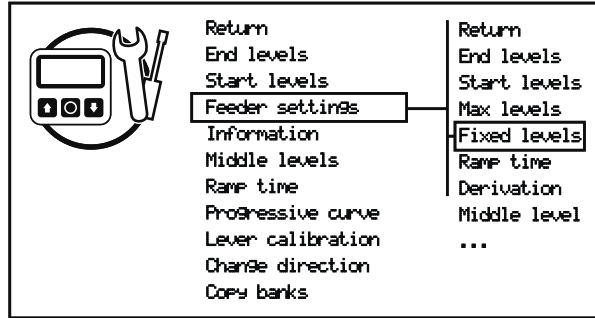
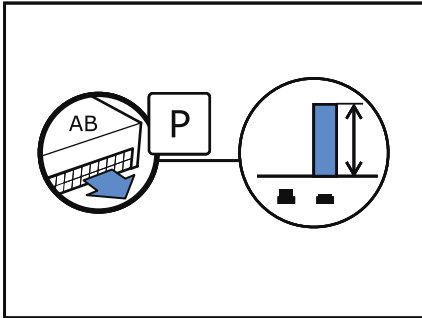

8.4 Feeder's Fixed Levels

The feeder's fixed levels are the signal levels emitted from the feeder output when a digital input signal activates the feeder.

1. To set or adjust a fixed level, select "Fixed levels" under "Feeder settings".

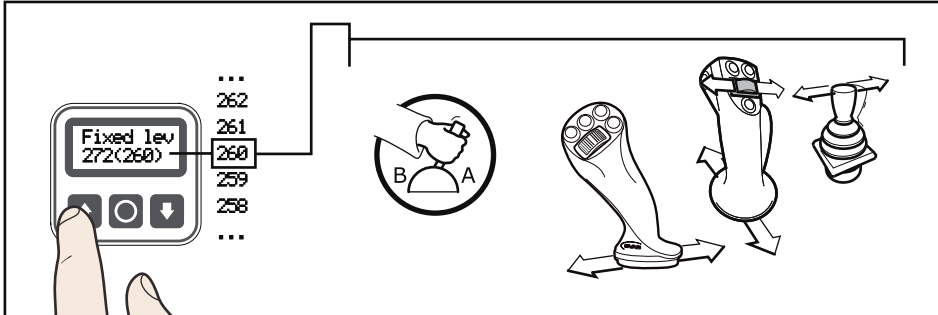

2. Set the desired value using the arrow keys, or moving the corresponding analog axis.

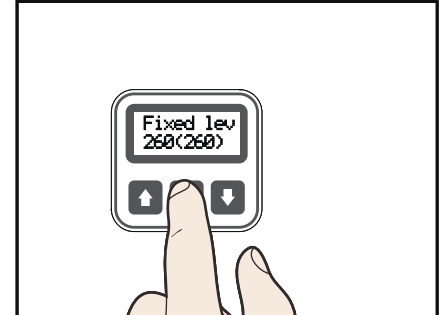

3. Save the value using the middle button. This value will be used for all fixed levels.

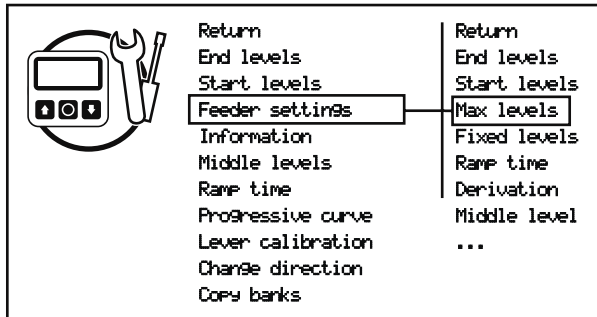
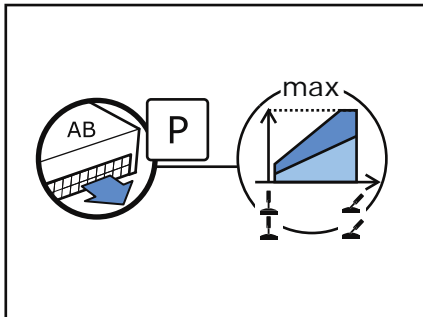

8.5 Feeder's Max Level

The max level regulates the upper limit that the feeder will open if several outputs are used simultaneously.

1. To adjust the max level, go to "Max level" under "Feeder settings".

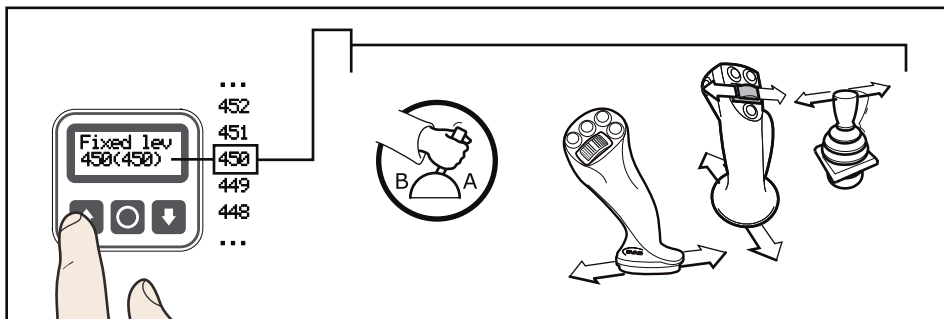

2. Set the appropriate value using the arrow keys.

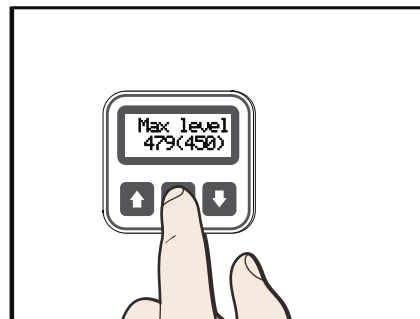

3. Save the value using the middle button.

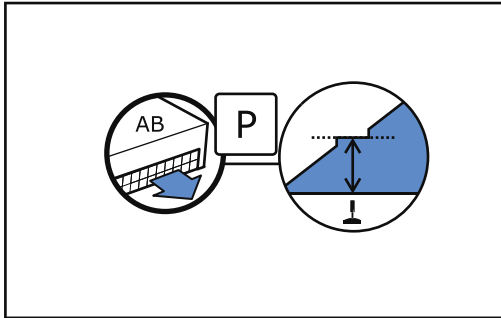

8.6 Middle Levels

The middle level is the signal level sent to an actuator when the lever controlling the actuator is in its middle position.

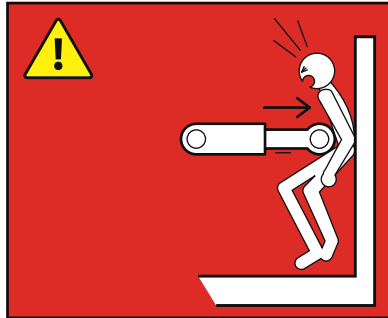

WARNING! When the middle level is set there is a high risk of unintentional movement. Ensure that the machine has plenty of room and that no persons are in the vicinity.

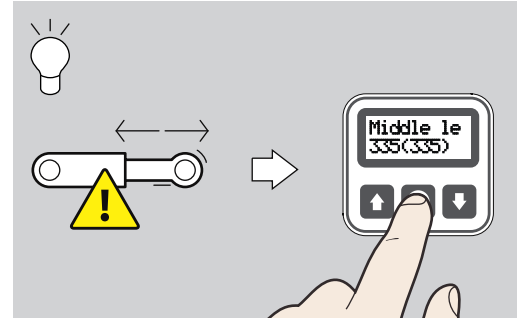

Should an unintentional movement occur during installation, you can always cancel the process by pressing the middle button. You will then be returned to the main menu.

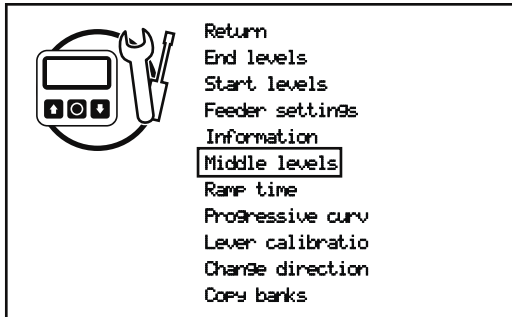

1. To set a middle level, select "Middle levels" in the main menu.

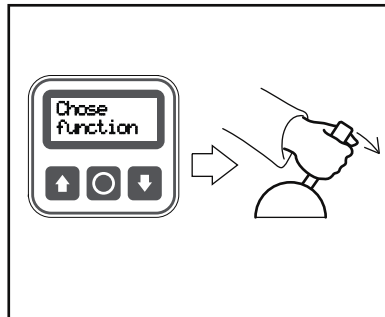

2. Select the output by pulling the analog axis that is programmed to control the output.

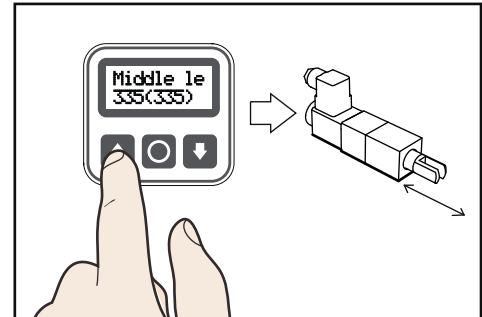

3. It is now possible to control the actuator backwards and forwards with the arrow keys.

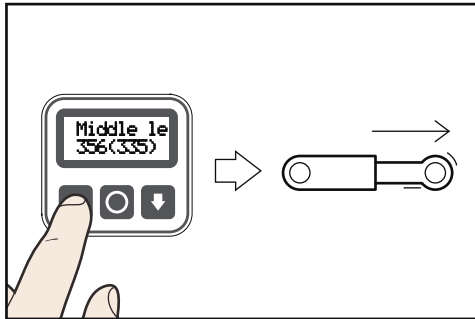

4. Note the hydraulic function that the valve controls. Press the up arrow key so that cylinder moves in either direction.

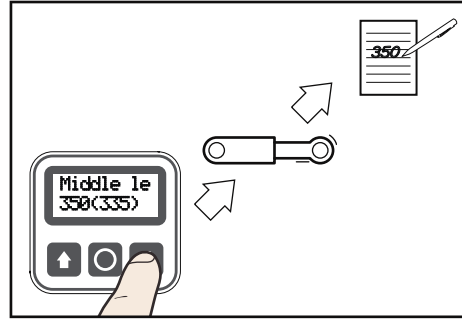

5. Use the down arrow key until the hydraulic cylinder is still but on the verge of moving. Note this value.

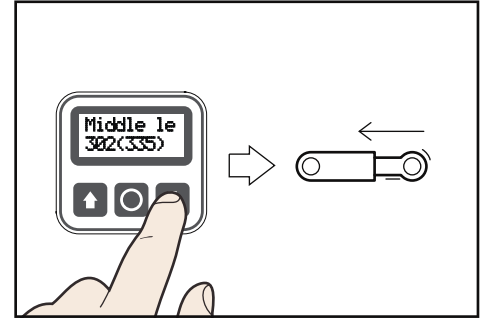

6. Now press the down arrow key so that cylinder moves in the opposite direction.

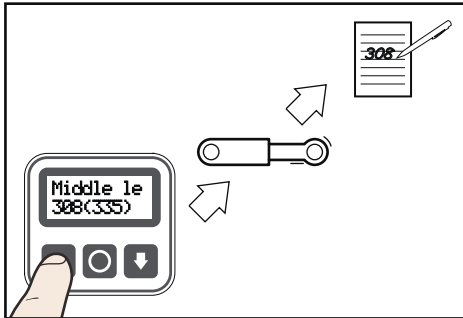

7. Use the up arrow key until the cylinder is again still but on the verge of moving. Note the value.

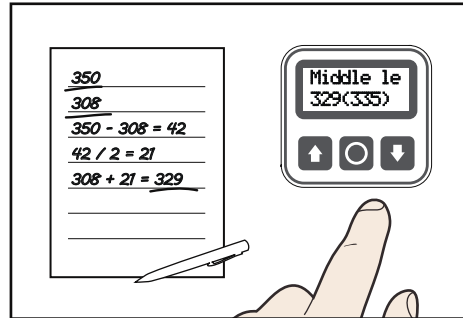

8. Set the middle level by determining the value that lies between the two values you have just attained (see example above).

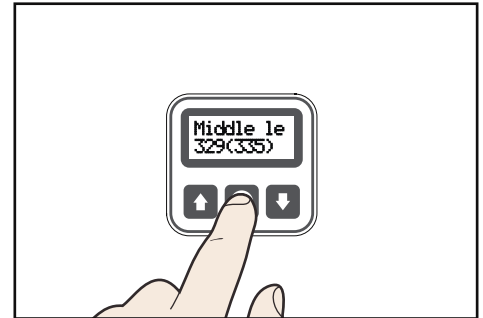

9. Input and save the value.

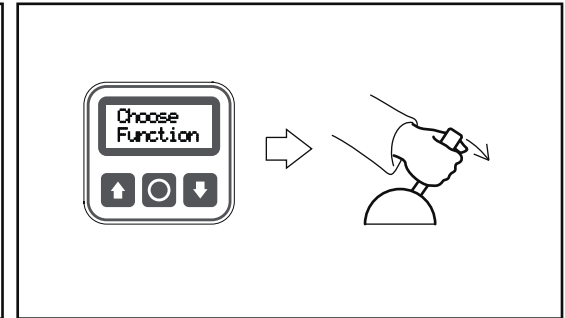
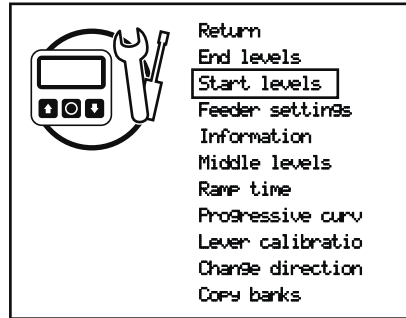
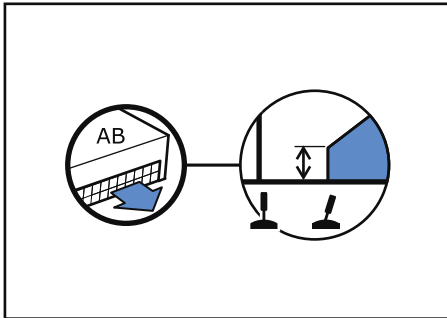

8.7 Start Levels

A start level is the signal level sent to the valve from the outputs when the associated analog axis is in its start position.

1. To set a start level, select "Start levels" in the main menu.

2. Select the output for which you want to set the start level for by pulling the analog axis that is programmed to control the output. Pull the lever in the direction for which the start level should be set.

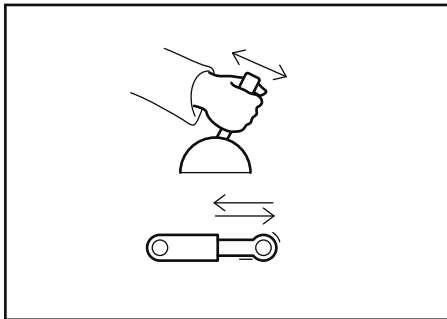

3. It is now possible to control the valve and the hydraulic function linked to the output.

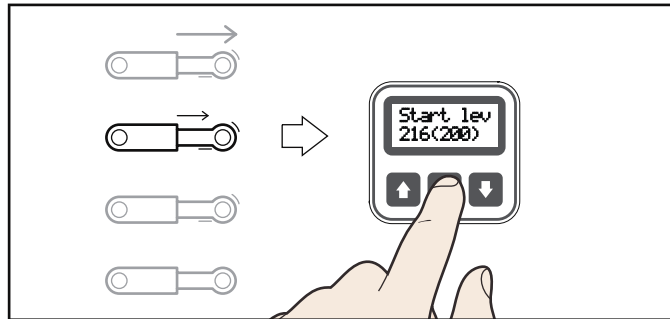

4. Hold the analog axis in such a position that the hydraulic cylinder moves at the slowest possible speed. Save the value by pressing the middle button. Now repeat this in the opposite direction and save the setting.

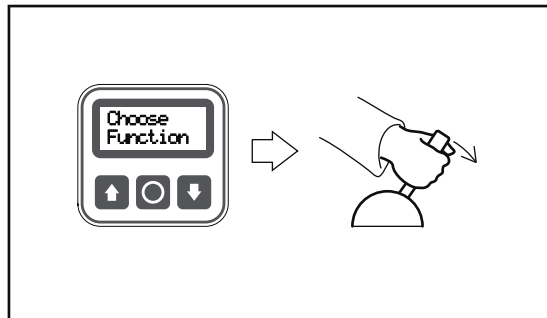
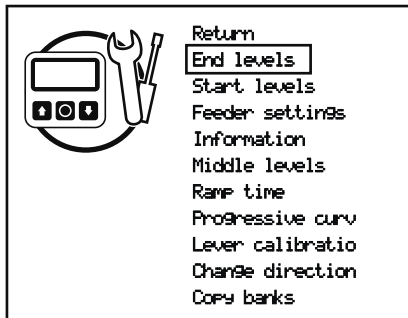
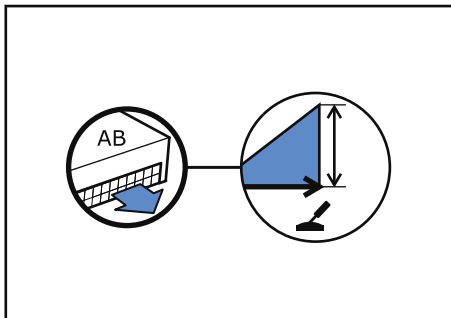

8.8 End Levels

An end level is the signal level that is sent from the output to the valve when the associated analog axis is in its end position.

1. To set an end level, select "End levels" in the main menu.

2. Select the output for which you want to set the end level for by pulling the analog axis that is programmed to control the output.

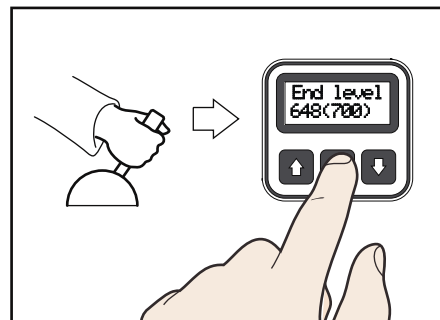
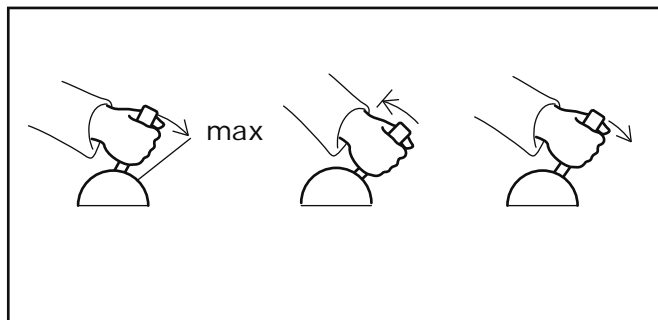
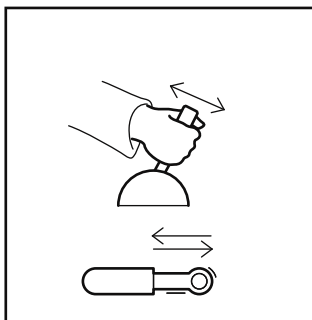

It is now possible to control the valve and the hydraulic function linked to the output.

3. Pull the analog axis to its end position. Release the lever until the valve starts to close, by observing that its speed decreases. Now increase slightly to find the position where the valve is fully open by a small margin.

4. Hold the analog axis in this position and save the value by pressing the middle button. Now repeat this in the opposite direction and save the setting.



9. Optional Settings

General:

This chapter is not mandatory. It describes settings and adjustments that are made in exceptional cases or when a problem occurs.

Chapter:

Page:

9.1 Lever Calibration.....	74
9.2 Hysteresis.....	76
9.3 Progressive Curve	77
9.4 Ramp Time	78
9.4.1 Ramp time, proportional outputs.....	78
9.4.2 Ramp time, on/off outputs	79
9.5 Ripple Amplitude.....	81
9.6 Change Direction	82
9.7 Derivation.....	82
9.8 Buzzer.....	83
9.9 Enter Code.....	84
9.10 Unlock Menus	85
9.11 Change the Code.....	85
9.11.1 Deactivate Menu Lock	85

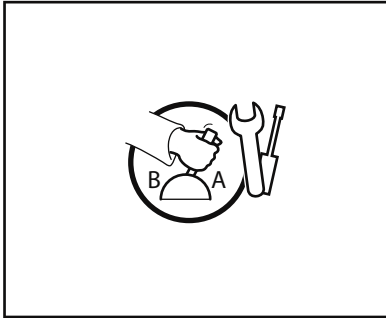

9.1 Lever Calibration

If a new lever is connected to the system, or if the first calibration was not successful, the lever should be recalibrated.

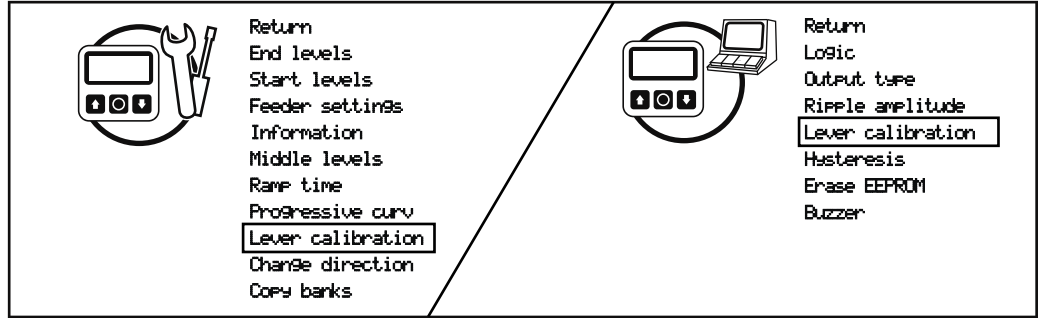

1. To recalibrate an analog axis:

For individual levers select "Lever calibration" in the main menu.

For all levers select "Lever calibration" in the master menu.

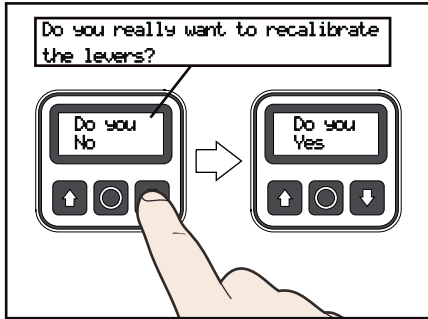

2. Press the down arrow for "Yes".



3. Confirm by pressing the middle button.

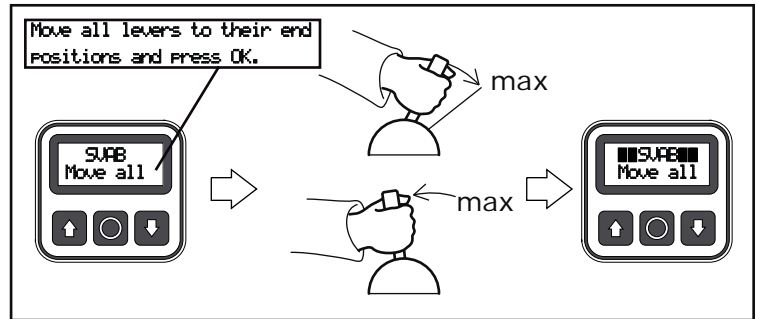

4. **Main Menu:** Slowly pull the chosen lever forwards and backwards to its end positions, and repeat this until the black squares on the display start flashing.

Master Mode Menu: Pull all levers slowly forwards and backwards to their end, and repeat this until the black squares on the display start flashing.

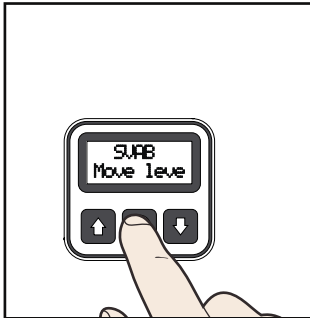

5. Confirm by pressing the middle button.

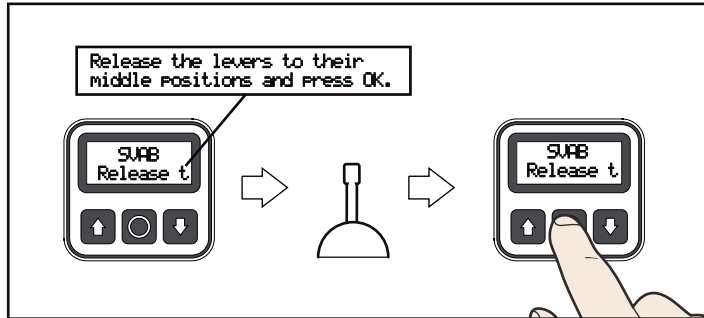

6. Release all levers to their middle position and confirm with the middle button. The levers are now calibrated.

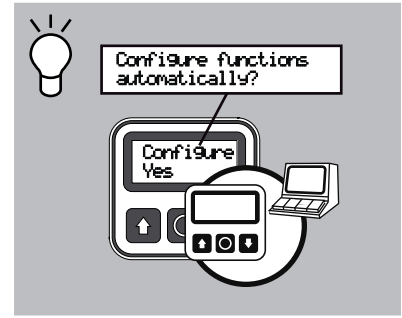

If a new analog axis has been added or removed during calibration using the **Master Mode Menu** then the GPC will detect this and can configure the new functions automatically if required.

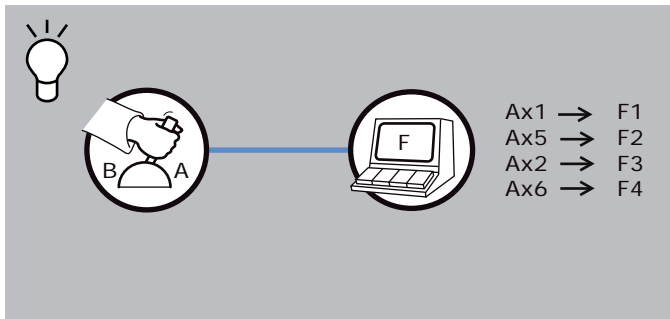

If the functions are configured automatically, the previous function settings will be deleted and replaced by the new settings. The list above describes how a system with four analog axis is linked by an automatic configuration.

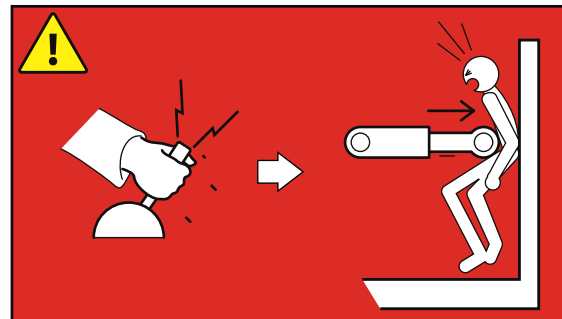

WARNING! During calibration it is important that the levers do not have any serious errors. Calibration of a faulty lever can result in incorrect control or incorrect movement.

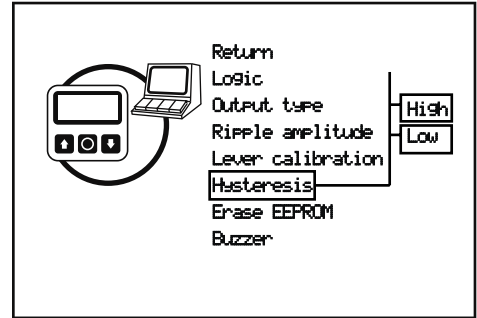
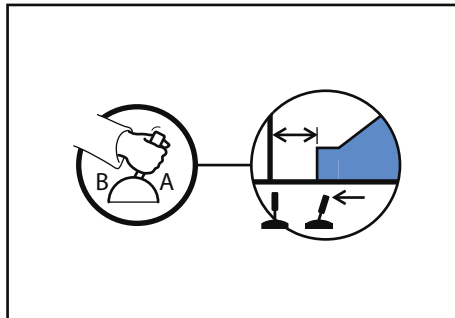
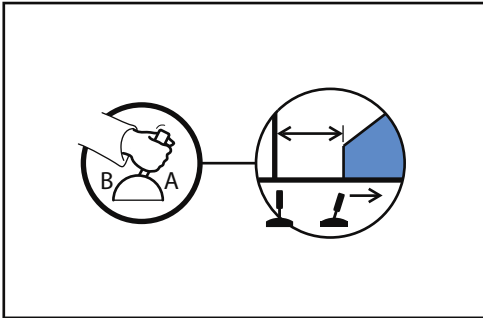

9.2 Hysteresis

Hysteresis determines the lever's play in the middle position. The High value determines how much you must pull the axis from the middle position before a signal is sent.

The Low value determines how far from the middle position you must release the lever before the signal is deactivated.

Select "Hysteresis" in the master mode menu. Now choose to set either "High" or "Low".

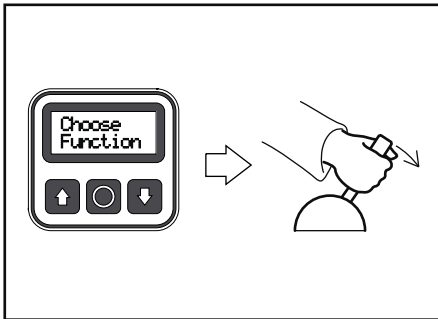

Choose the analog axis to be set by pulling the lever that controls the desired function.

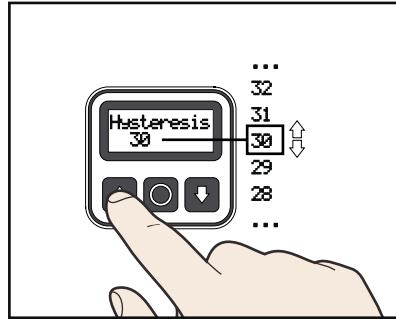

Set the required value using the arrow keys and confirm with the middle button to save.

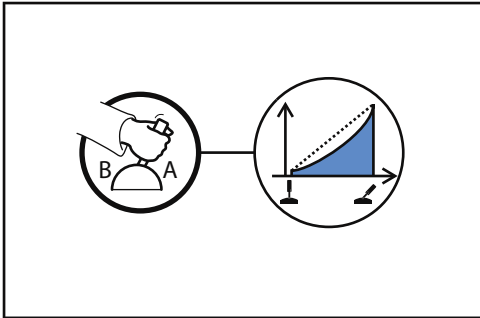

9.3 Progressive Curve

When you would like to improve the creep operating characteristics, use the Progressive Curve setting

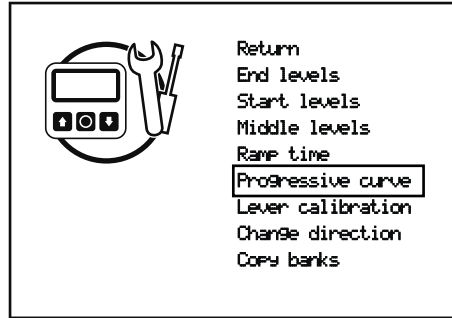

To set the desired progression, select "Progressive curve" in the main menu.

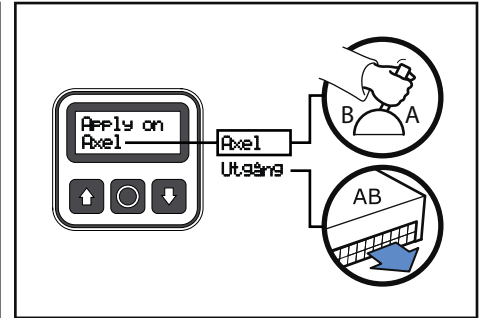

Choose whether to configure progression for a lever or an output.

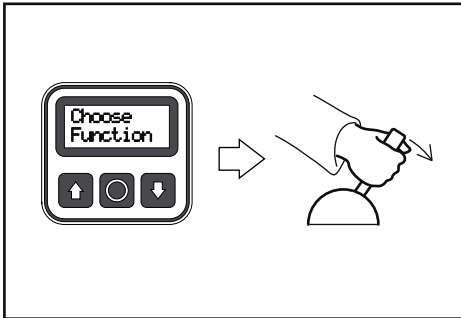

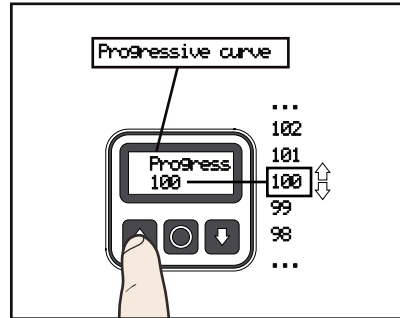

Pull the analog axis for which progression is to be set.

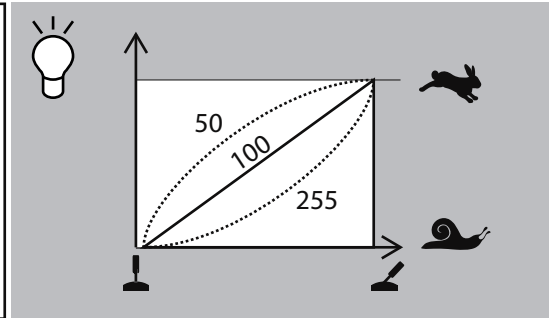

Set the desired curve with the help of the arrow keys. Save with the middle button and return to the main menu.

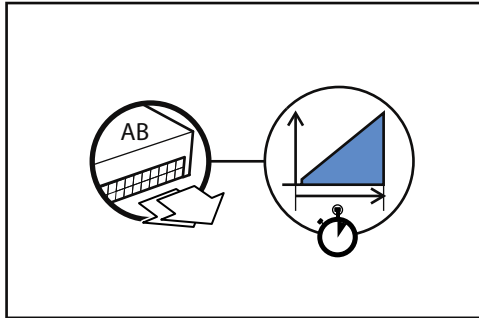
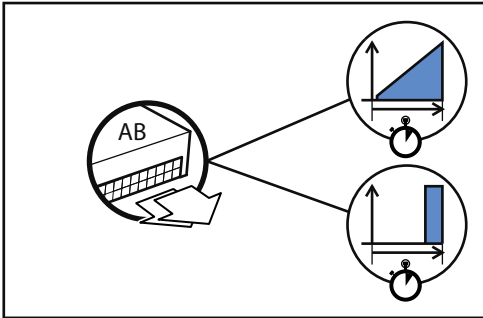

The figure above shows the relation between the lever movement and the speed of the hydraulic function when controlled by three different setting values.

- Return
- End levels
- Start levels
- Information
- Middle levels
- Ramp time**
- Progressive curve
- Lever calibration
- Change direction
- Copy banks

9.4 Ramp Time

Ramp time is set up differently depending on the type of output. See 9.4.1 and 9.4.2 for detailed explanations.

9.4.1 Ramp time, proportional outputs

For proportional outputs (Out1-5) ramp time is the time it takes for the output's signal to change from the start level to end level when the lever is pulled from the middle position to the end position.

1. To set a ramp time, select "Ramp time" in the main menu.



Return	Return
End levels	End levels
Start levels	Start levels
Feeder settings	Max levels
Information	Fixed levels
Middle levels	Ramp time
Ramp time	Derivation
Progressive curve	Middle level
...	...

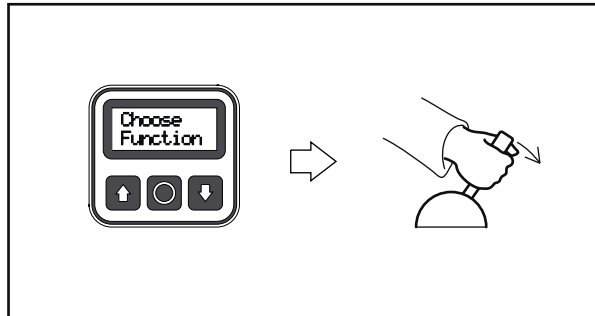

Ramp time can also be set for a feeder if the system is equipped with one. If so, "Ramp time" is a submenu to "Feeder settings" in the main menu.

2. Select the output for which ramp time is to be set by pulling the lever that controls the output. If several outputs are linked to the lever, you must select the output using the arrow keys.

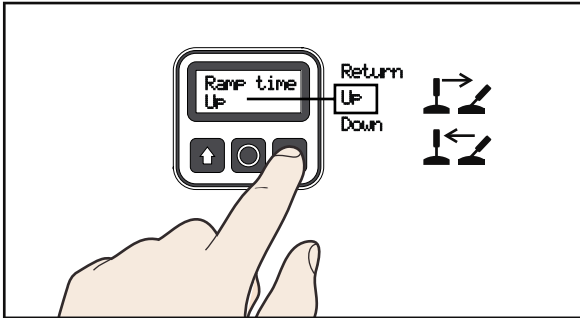

3. The ramp time can be set when the lever is pulled from the middle position to the end position (*Up*) or when released from the end position to middle position (*Down*). Select the option with the arrow keys and confirm with the middle button to continue.

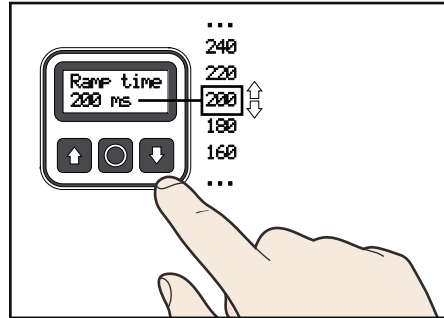

4. Adjust the time using the arrow keys and save. A system with longer ramp times is softer but less responsive; a system with shorter times is jerky but more responsive.

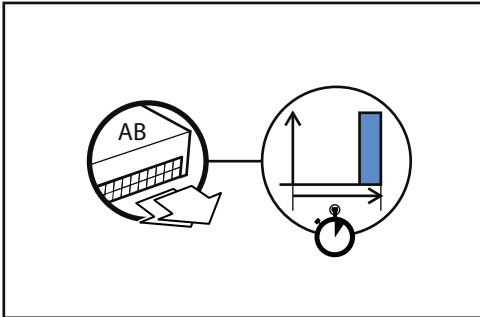

9.4.2 Ramp time, on/off outputs

For on/off outputs (Out6-9) ramp time functions as a switch on or switch off delay.

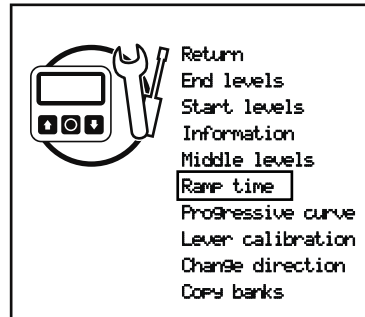

1. To set ramp time, choose "Ramp time" in the main menu.

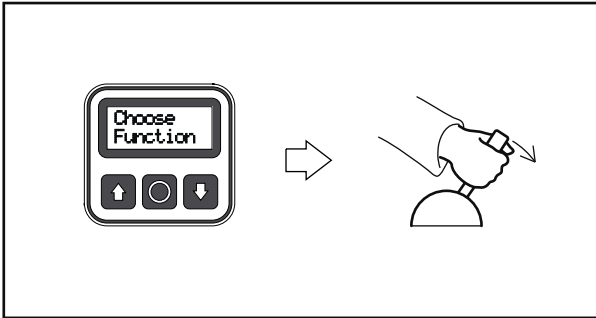

2. Select the output for which ramp time is to be set by pulling the lever that controls the output. If several outputs are linked to the lever, you must select the output using the arrow keys.

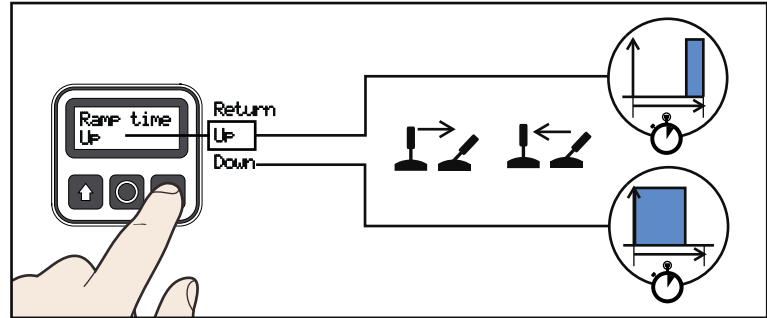

3. (*Up*) - The time that the input signals must be active before the output is activated (on switching delay)

(*Down*) - The time that the output remains active after the input signal is turned off (off switching delay).

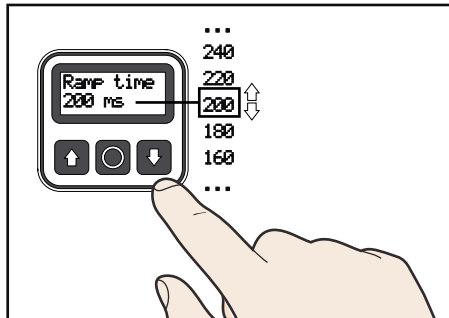

4. Adjust the ramp time using the arrow keys and save.

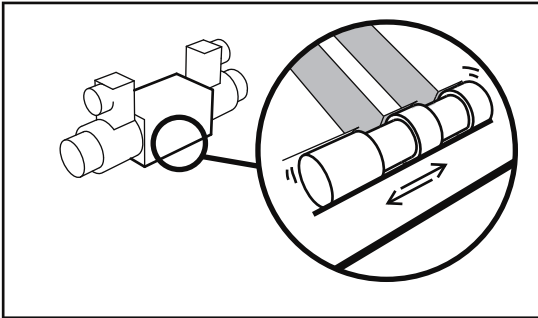

9.5 Ripple Amplitude

Ripple is a signal that vibrates the valve slide so that it can be controlled without jerkiness when it begins moving.

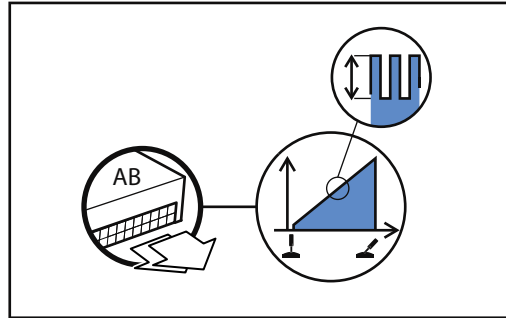

The ripple amplitude determines how strong the vibration should be. The signal from the outputs is overlaid with a square wave. The larger the square wave the greater the vibration.

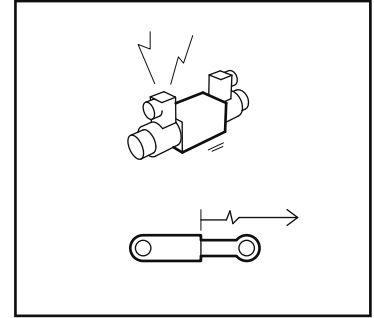

The amplitude is set too high if the valve makes sounds and vibrates heavily and too low if the hydraulic cylinder's movement is delayed or jerky.

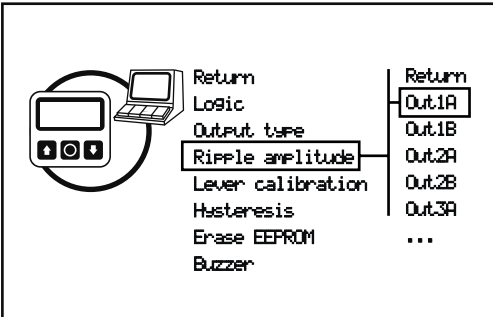

1. To change the ripple amplitude select "Ripple amplitude" and then the output to be set.

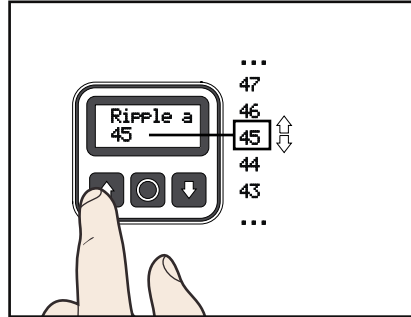

2. Increase or decrease the ripple amplitude using the arrow keys. Save the required value by pressing the middle button.

Note!
An incorrectly adjusted Ripple Amplitude can after a while cause material damage or personal injury.

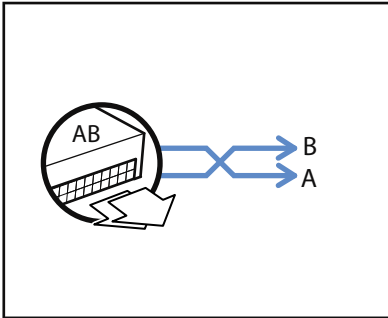

9.6 Change Direction

If required, the signals from a double-acting output can be reversed so that the valve is controlled in the opposite direction.

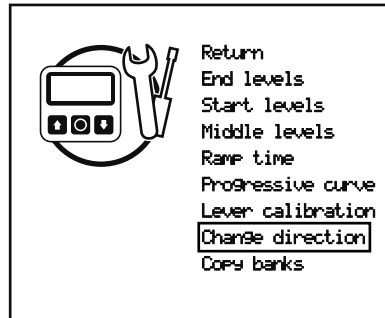

1. Select "Change direction" in the main menu.

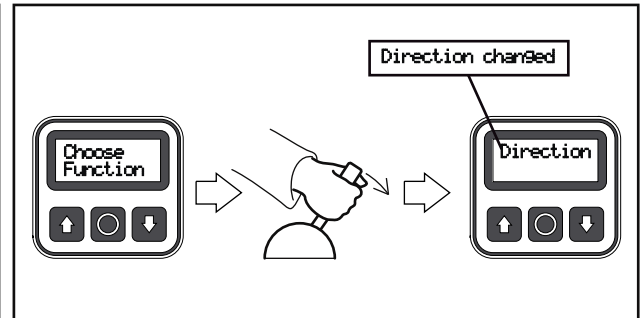

2. Now select the output for which to change the direction of by pulling the lever that is linked to the output. The direction is then changed. Confirm with the middle button and return to the main menu.

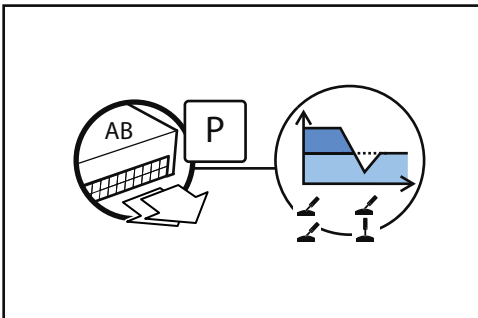

9.7 Derivation

Oversteer is used to get the feeder to control the return faster when a lever is moved back. The oversteer can be set using a derivation factor.

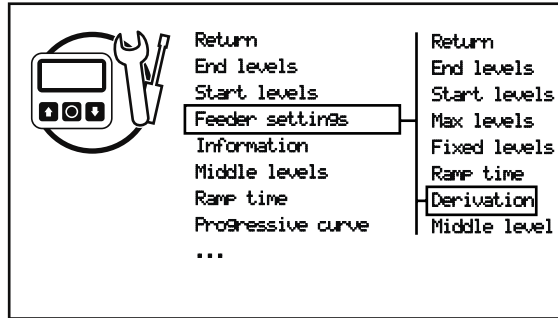

1. To set the derivation factor, select "Derivation" under "Feeder settings" in the main menu.

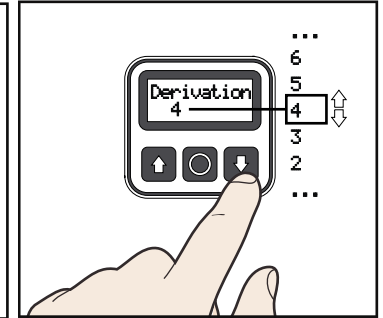

2. Adjust the desired derivation factor using the arrow keys and save with the middle button. You will return to the feeder settings menu.

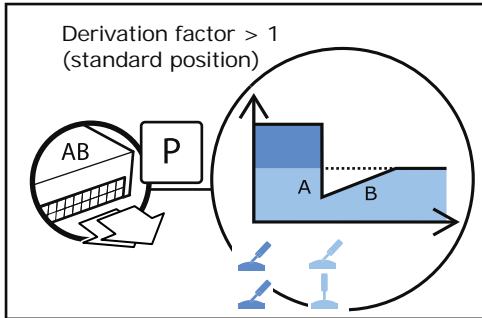

A: The derivation factor decides how low the output signal should be.
 B: The feeder's down-ramp time states the output signal's "recovery time", or the time after the signal is oversteered until it returns to its normal level.

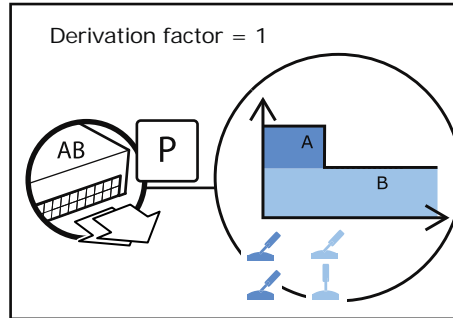

A: No oversteer occurs.
 B: The feeder's down-ramp time is not used at all.
 E.g. the value is 1, there is no down ramp and no oversteer occurs.

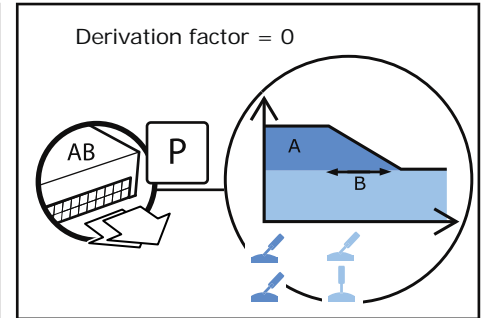

A: No oversteer occurs.
 B: The feeder's down-ramp time is used to ramp down to the required level.
 E.g. the value is 0, there is no oversteer, and down ramping is used from the higher level to the correct level.

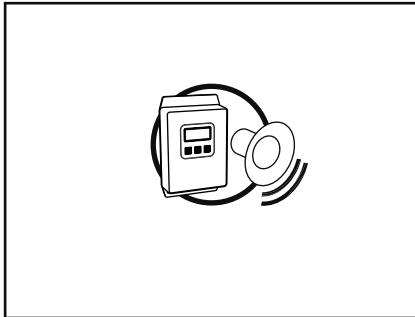

9.8 Buzzer

The GPC is equipped with a buzzer.
 The buzzer volume can be adjusted.

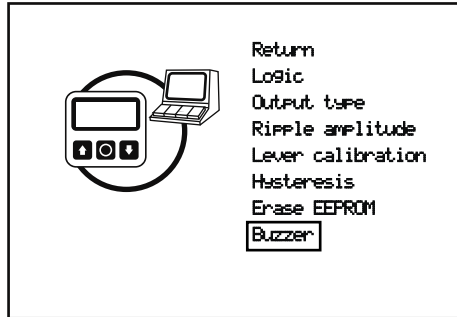

To adjust the buzzer volume select "Buzzer" in the master mode menu.

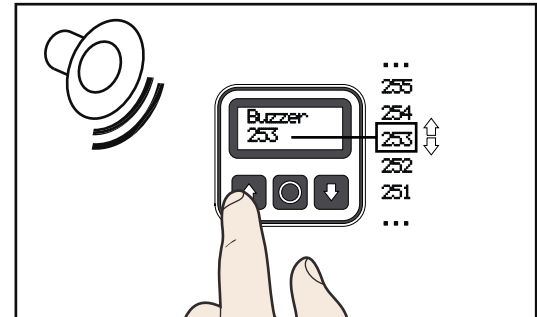

Adjust the buzzer volume using the arrow keys.
 The value 255 gives the highest volume. Quit and save the settings with the middle button.

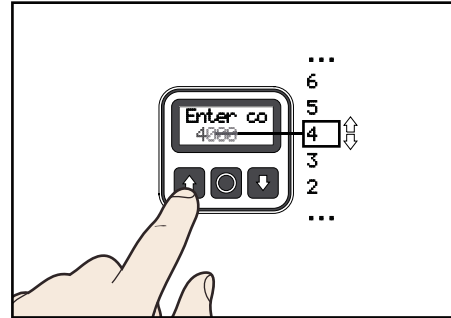
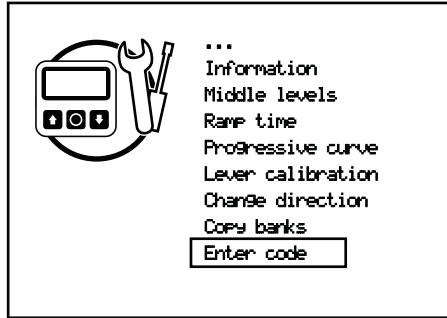
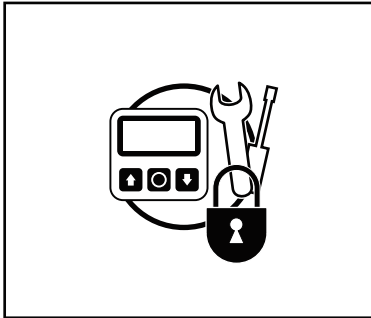

9.9 Enter Code

It is possible with the help of a PIN code to lock certain menus so that changes cannot be made.

A summary of the menus that will be locked is shown in the figure *Summary menu lock*, on page 86. To lock menus, select "Enter code" in the main menu.

1. Select a PIN code using the arrow keys.

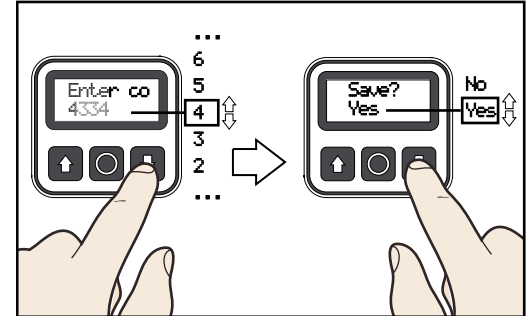
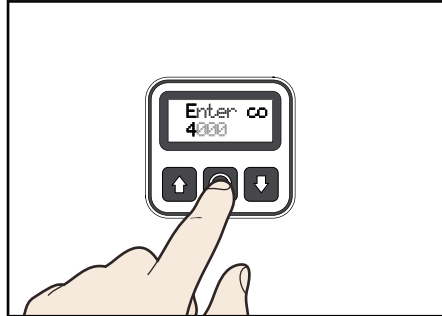
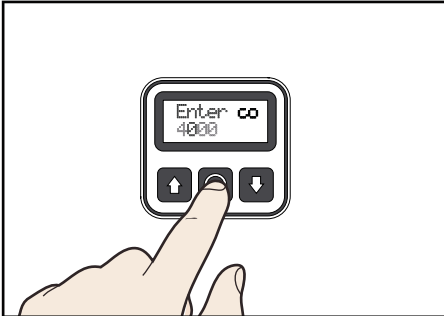

2. Confirm each digit and proceed to the next digit using with the middle button.

3. To backspace, press and hold in the middle button. Repeat step 1 and 2.

After successfully entering a 4 digit PIN code, save with the middle button and then select yes when asked *Save?* Parts of the menu system is now locked. Locked menus are listed in the figure *Summary menu lock*, page 86.

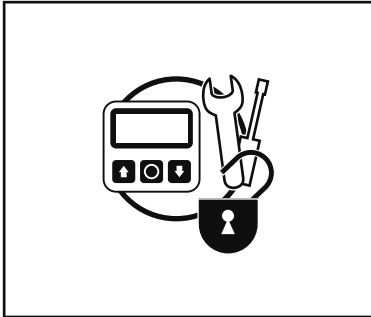

9.10 Unlock Menus

Locked menus are unlocked by using the PIN code entered when the menus were locked.

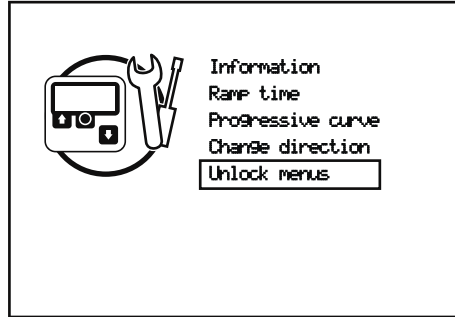

When the menus are locked, "Unlock menus" is shown in the main menu. To gain access to locked menus, select "Unlock menus" in the main menu.

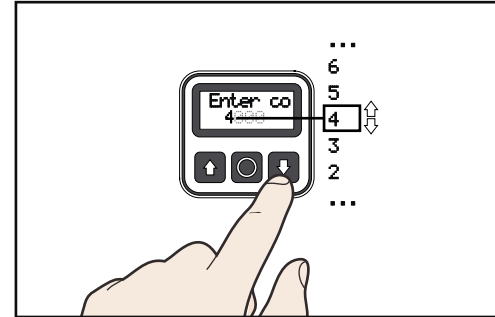

Enter the PIN code and press the middle button. Entering the correct PIN code automatically returns to the main menu. Five incorrect attempts locks the system. Contact SVAB and state the response code shown.

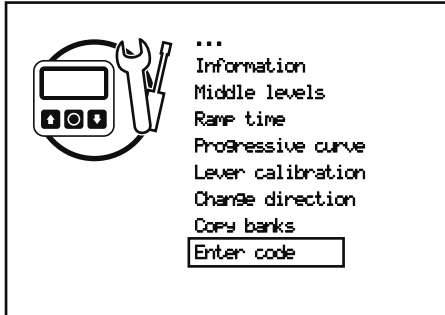

9.11 Change the Code

To change the PIN code, first the menu system must be unlocked. A new PIN code is then entered as in 9.9 Enter Code. If a new PIN code is not entered, the menus will again be locked on the next start-up and the previous PIN code continues to apply.

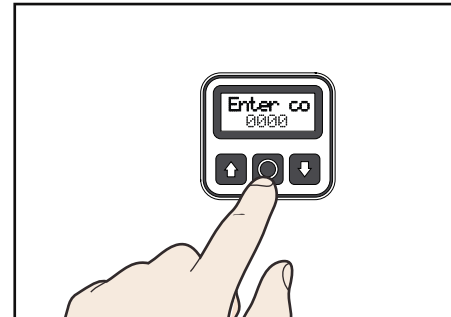

9.11.1 Deactivate Menu Lock

To Deactivate Menu Lock and erase the existing PIN code, unlock using your PIN code, then change the PIN code to 0000 (four zeros). The menus are now unlocked until a new PIN code is entered.

Summary Menu Lock

The locked menus are shown as striken through, while the other menus remain unlocked.



Main menu

```

Return
End levels
Start levels
Feeder settings
  Return
  End levels
  Start levels
  Max levels
  Fixed levels
  Ramp time
  Derivation
  Middle level
Information
  Return
  Firmware version
  Serial number
  Show stored error codes
  Erase stored error codes
Middle levels
  Ramp time
  Progressive curve
Lever calibration
  Change direction
Copy banks
  Unlock menus
  
```



Mastermode menu

```

Return
Logic
  Return
  In-test
  Functions
  Outputs
  Double push
Output type
Ripple amplitude
Lever calibration
Hysteresis
Erase EEPROM
Buzzer
  
```

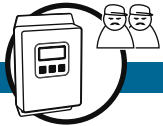

10. Configuration Banks

What is a configurations bank?

When you make a setting, the new value for the setting is saved in the current configuration bank.

Which settings are saved and where?

All settings are saved in the bank that is active when the settings are made. Four exceptions are the settings for *Hysteresis*, *Progressive curve*, *Lever calibration* and *Buzzer* which are saved in the common memory.

What can the banks be used for?

When you switch drivers or attachments you can easily change the settings by using another bank.

Chapter:

10.1 Current Configuration Bank	88
10.2 Change Configuration Bank.....	88
10.3 Copy Banks	88

Page:



Tips!

To reset all settings to the default settings, use *Erase EEPROM*, chapter 11.7

If you only want to reset some of the settings, you can find the default values listed in Appendices 2-4.

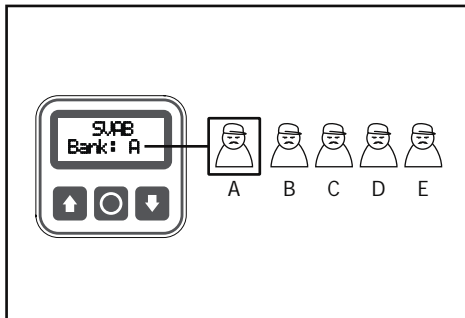

10.1 Current Configuration Bank

The GPC has five banks. These are called A, B, C, D and E. The current bank is shown while in the operating mode.

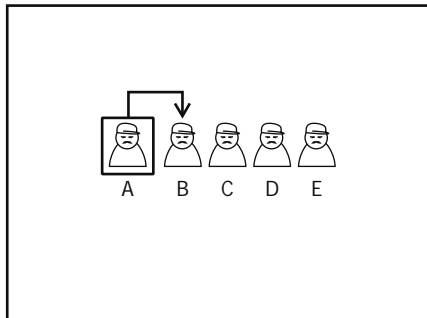

10.2 Change Configuration Bank

To adapt the control system to different drivers or attachments you can switch banks.

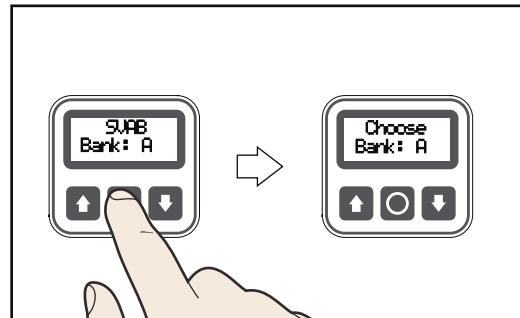

1. It is very easy to change banks. Simply press the middle button.

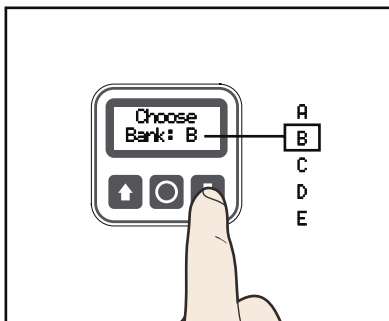

2. Scroll with the arrow keys to the desired bank.

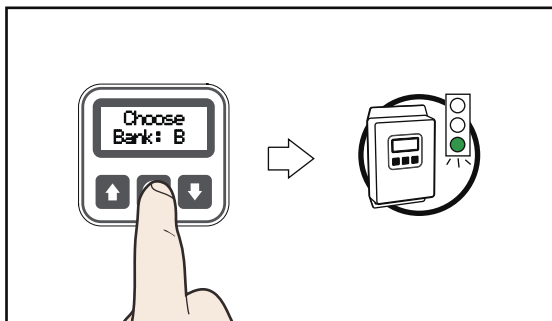

3. Select the chosen bank with the middle button and return to the operating mode.

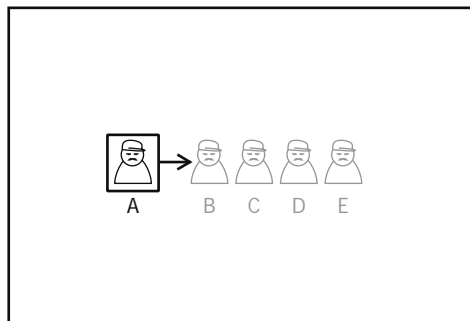

10.3 Copy Banks

Once you have made and saved your settings, it is possible to copy these to one of the other banks.

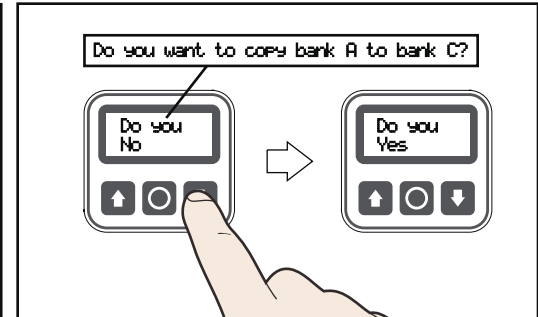
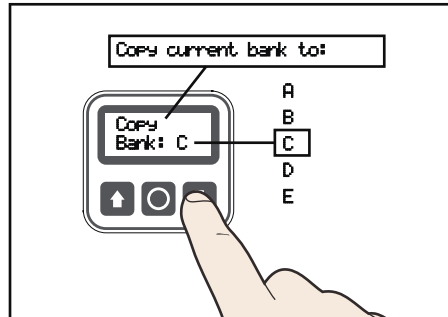
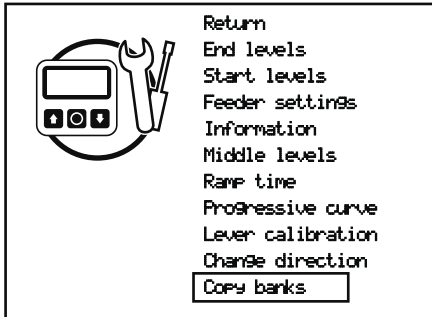

1. Make sure the bank you wish to copy is the current bank. Now select "Copy banks" in the main menu.
(In the example above bank A is the current bank.)

2. Select the bank to which you wish to copy the bank to by using the arrow keys, e.g. copy Bank A to Bank C.

3. Use the down arrow to switch to "Yes".

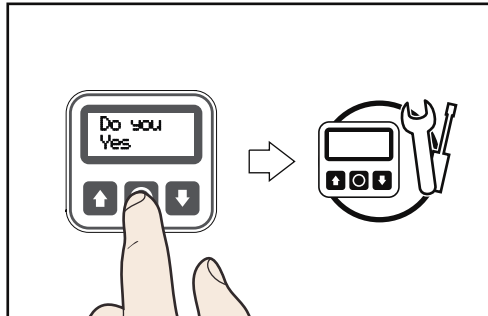

4. Press the middle button to copy the selected bank and return to the main menu.



1.1. Troubleshooting

General:

The GP Controller (GPC) can detect many system errors. The output related to an error is shut down so that no dangerous situations can occur. For most errors it is sufficient to release the lever so that the output will be activated again.

When a error is detected a four digit error code is displayed. Error codes and suggested solutions are described in the following list.

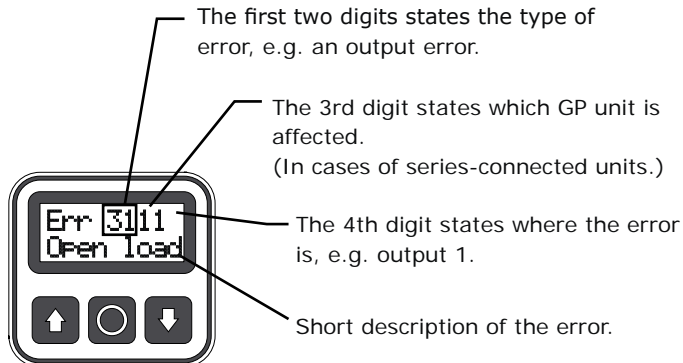

The first two digits states the type of error, e.g. an output error.

The 3rd digit states which GP unit is affected.
(In cases of series-connected units.)

The 4th digit states where the error is, e.g. output 1.

Short description of the error.

Troubleshooting instructions:

1. Determine the type of error and where it is located.

Perform the solution.

Note: Errors are frequently wiring related.

2. If the error persists contact SVAB. Prepare by noting your GPC's firmware version and serial number. It can also be a good idea to check the stored error messages.

Chapter:

Page:

11.1 Input Signal Error	92
11.2 System Error	92
11.3 Output Error	93
11.4 CAN-error	93
11.5 Show Stored Error Codes	94
11.6 Erase Stored Error Codes	94
11.7 Erase EEPROM	95
11.8 Serial Number	95
11.9 Firmware Version	95



11.1 Input Signal Error

An input signal error is an error somewhere between the lever and the GPC. The error is usually due to bad electrical contact or a pinched cable.

Type:	Cause:	Solution:
11	The lever's signal is outside of the calibrated end positions. May be due to a lever error or incorrect calibration.	Try to recalibrate the lever if it works in some positions. Check the cabling if the lever does not work at all.
12	Incorrect lever sensor sum. Probably due to bad contact or a defective lever sensor.	Check the cabling, rectify any bad contact(s).
13	Defective microswitch. The lever's microswitch is not working properly in relation to the lever's analog sensor. Probably due to bad contact or a defective microswitch.	Check the cabling, rectify any bad contact(s).
14	A digital input signal (pulse monitor circuit) is short-circuited to ground.	Check that DX_IN is connected to DX OUT and not to ground.
15	1) One of the input signals is above 4.75 V or below 0.25 V during lever calibration. 2) Poor linearity between X-signals. 3) Incorrect center position calibration (error code is displayed only if the middle button is pressed after center position calibration).	Check the cabling, rectify any bad contact(s).

11.2 System Error

The system contains three microprocessors, each verifying the other. Thus, occurring errors can be detected and reported.

Type:	Cause:	Solution:
70	Memory error.	Contact SVAB.

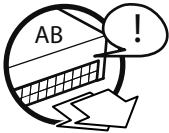

11.3 Output Error

The system can detect different errors on the outputs, e.g. a short-circuit.

Type:	Cause:	Solution:
30	Short-circuit on one of the proportional outputs.	Check that wiring is correctly fitted. Check for wire damage.
31	Open circuit on one of the proportional outputs.	Check for wire damage. Check that all connectors are coupled correctly.
32	Current response error. The supplied current and amperage do not correspond. May be due to high inductance in the coil, an overheated coil, saturated coil, saltwater in the magnetic switch or low input voltage.	Check connections, grounding and supply voltage.
33	Short circuit on one of the on/off outputs.	Check for wire damage. To activate the output again, enter and exit the main menu.
34	Open circuit on one of the on/off outputs.	Check that all the connectors are coupled correctly. Check for wire damage.
35	The coupler (tool lock) circuit is closed but the activation signal is not active. (If the coupler's activation signal isn't active, its ground should open).	Check the coupler and its connections. Error may be caused by creeping current from an output to ground, e.g. moisture in the connectors.



11.4 CAN-error

If your system is equipped with modules that communicate via CAN (Control Area Network), then errors related to the function of the bus may occur. This may be due to a wiring error or an error in one of the units.

Type:	Cause:	Solution:
90	CAN-unit timeout. Error code's last two digits state which unit is in fault, e.g. 9002 for unit 0x02 or 9034 for unit 0x34.	Check for wire damage. Check that all connectors are coupled correctly and that all units are connected to the power supply.

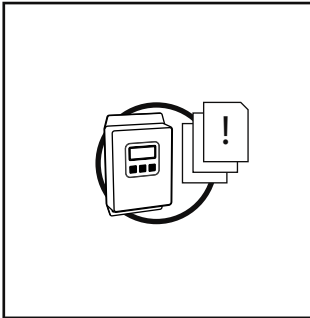

11.5 Show Stored Error Codes

To help trouble shooting, up to 10 error codes are saved. New stored codes replace the older stored codes.

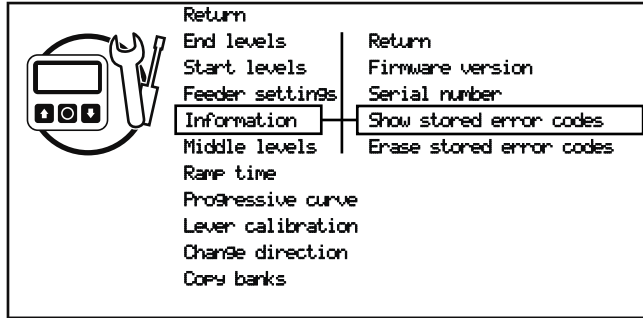

1. To display stored error codes, select "Show stored error codes" under "Information" in the main menu.

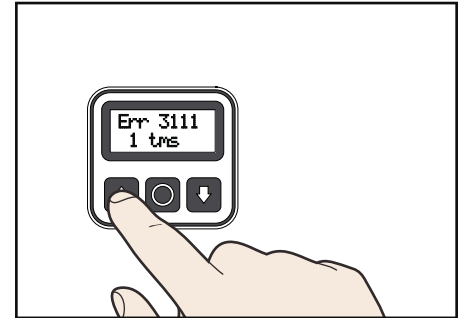

2. Scroll the error codes using the arrow keys and the middle button to exit. Error codes are displayed one at a time, most recent first and the number of times in a row a particular error has occurred.

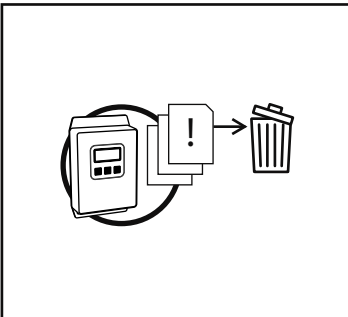

11.6 Erase Stored Error Codes

It is only possible to stored error messages if the preceding error codes have been viewed.

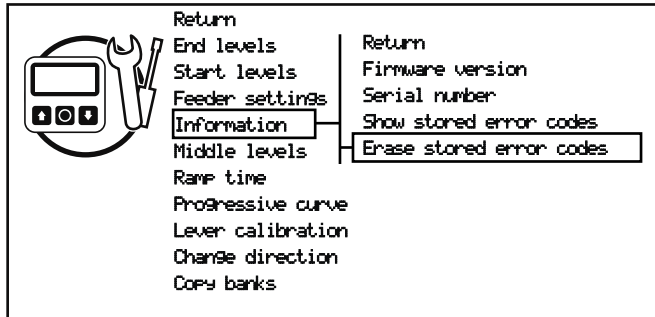

1. To delete stored error codes select "Erase stored error codes" under "Information" in the main menu.

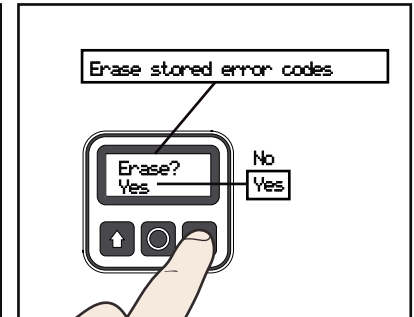

2. Use the down arrow to select "Yes" and confirm with the middle button.

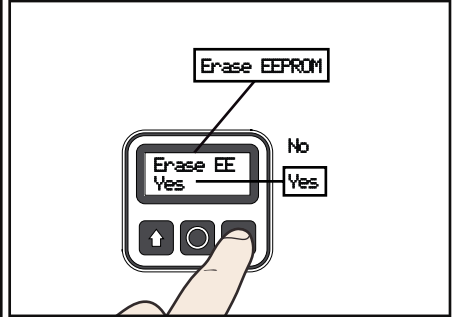
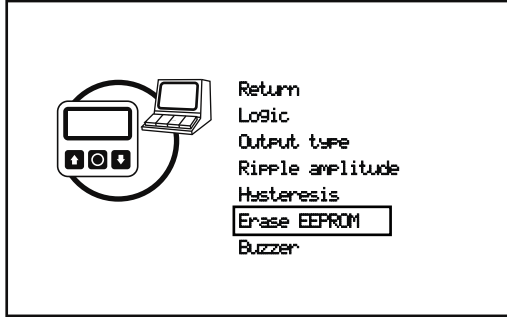
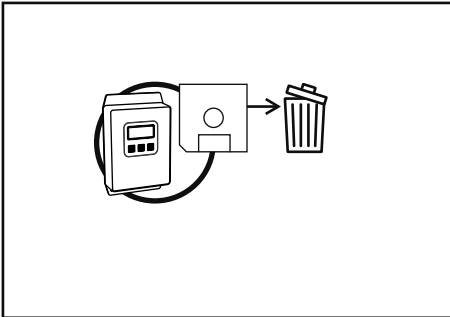

11.7 Erase EEPROM

This option restores all settings to the default values. When the EEPROM-memory is erased the system restarts and start up settings must be made again.

1. To erase the EEPROM memory select "Erase EEPROM" on the master mode menu.

2. Use the down arrow to select "Yes" and confirm with the middle button.

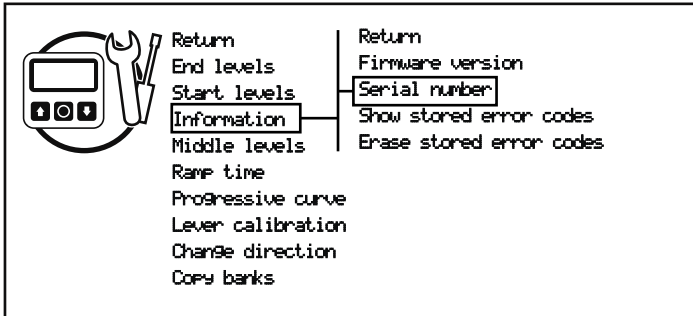

11.8 Serial Number

To display the GPC's serial number, select "Serial number" under "Information" in the main menu. The number is also printed on the top edge of the original packaging box.

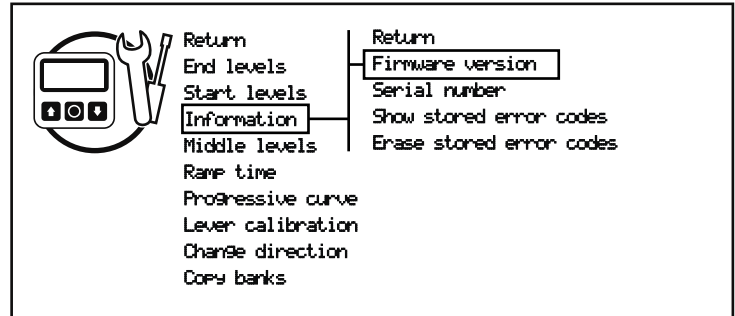

11.9 Firmware Version

To display the GPC's firmware version number and date it was distributed, select "Firmware version" under "Information" in the main menu.

Appendix 1. Connections

Input ports

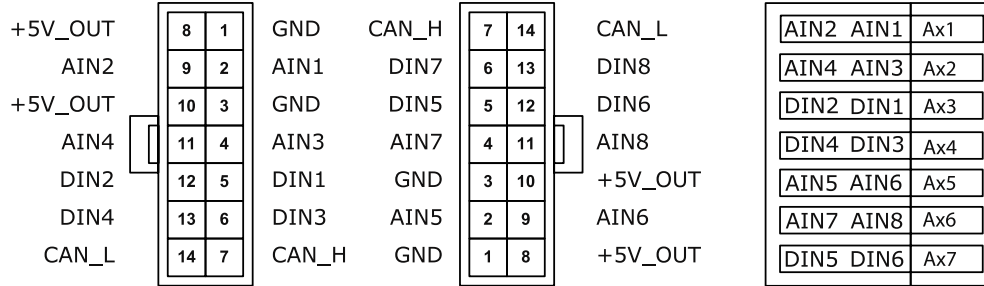

Output ports

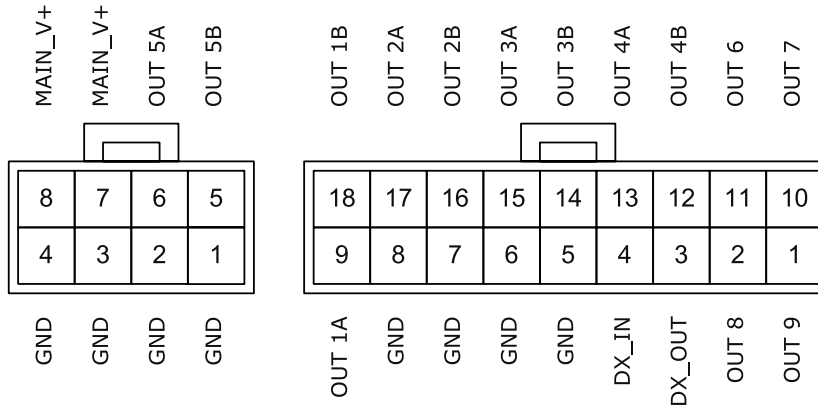

Appendix 2. Common Default Settings

Settings for axes:		Ax1	Ax2	Ax3	Ax4	Ax5	Ax6	Ax7
Progressive curve		100	100	100	100	100	100	100
Hysteresis (1)	High	30	30	30	30	30	30	30
	Low	15	15	15	15	15	15	15
Hysteresis (2)	High	100	100	100	100	100	100	100
	Low	75	75	75	75	75	75	75

1. Default setting for analog axis with microswitch.
2. Default setting for analog axis with double analog crossed signals.

Other settings

Buzzer	255
--------	-----

What is meant by default settings?



Default settings are the preprogrammed values in the GPC. Changing settings replaces these. To restore all settings to the default settings, use *Erase EEPROM*, see chapter 11.7.

What is meant by common settings?

Common settings are the changes to the above default settings and are saved in the common memory. Accordingly, these settings apply even to a bank change.

Output settings:	Out1	Out2	Out3	Out4	Out5		Out6	Out7	Out8	Out9
Output type	V-function	V-function	V-function	V-function	Feeder A		On/Off	On/Off	On/Off	Coupler
Current monitoring	On	On	On	On	On		On	On	On	On
End level direction A/B	700/700	700/700	700/700	700/700	for Out1:	360/360				
					for Out2:	360/360				
					for Out3:	360/360				
					for Out4:	360/360				
					for Out6:	360/360				
					for Out7:	360/360				
					for Out8:	360/360				
for Out9:	360/360									
Start level direction A/B	200/200	200/200	200/200	200/200	210					
Max level					450					
Fixed levels					360					
Derivation					4					
Ramp time up/down	200/200	200/200	200/200	200/200	400/200		0/0	0/0	0/0	0/0
Change direction	off	off	off	off						
Ripple amplitude	45	45	45	45	18					

DIN-settings:	DIN1	DIN2	DIN3	DIN4	DIN5	DIN6	DIN7	DIN8	DINX
Double push	off	off	off	off	off	off	off	off	off



What is meant by default settings?

Default settings are the preprogrammed values in the GPC. Changing settings replaces these. To restore all settings to the default settings, use *Erase EEPROM*, see chapter 11.7.

What can settings be used for?

The default settings in banks A, C, D and E are a suitable starting point when setting up a tilt rotator.

Settings in Logic, Functions

(With automatic configuration and Ax1, Ax2, Ax5 and Ax6 connected.)

	F1	F2	F3	F4	F5	F6	F7	F8	F9	F10	F11	F12
Ax1	+											
Ax2			+									
Ax5		+										
Ax6				+								
Ax3	DIN1											
	DIN2											
Ax4	DIN3											
	DIN4											
Ax7	DIN5											
	DIN6											
DIN7												
DIN8												
DINX												
F1												
F2												
F3												
F4												
F5												
F6												
F7												
F8												
F9												
F10												
F11												
F12												
Import												

Settings in Logic, Outputs

2:2

		Out1	Out2	Out3	Out4	Out5*	Out6	Out7	Out8
F1	A	✓✓				Out1A	✓		
	B	✓✓				Out1B	✓		
F2	A		✓✓			Out2A	✓		
	B		✓✓			Out2B	✓		
F3	A			✓✓		Out3A	✓		
	B			✓✓		Out3B	✓		
F4	A				✓✓	Out4A			
	B				✓✓	Out4B			
F5	A					Out6			
	B					Out7			
F6	A					Out8			
	B					Out9			
F7	A								
	B								
F8	A								
	B								
F9	A								
	B								
F10	A								
	B								
F11	A								
	B								
F12	A								
	B								
DIN1									
DIN2									
DIN3									
DIN4									
DIN5									
DIN6									
DIN7									
DIN8									
DINX									✓✓

*An output set as feeder is controlled by other outputs and digital input signals.

Appendix 4. Default Settings Bank B

1:2

Output settings:	Out1	Out2	Out3	Out4	Out5	Out6	Out7	Out8	Out9
Output type	Actuator A	Actuator A	Actuator A	Actuator A	Actuator A	On/Off	On/Off	On/Off	On/Off
Current monitoring	Pá	Pá	Pá	Pá	Pá	Pá	Pá	Pá	Pá
End level direction A/B	120/120	120/120	120/120	120/120	120/120				
Start level direction A/B	30/30	30/30	30/30	30/30	30/30				
Middle level	335	335	335	335	335				
Ramp time up/down	200/200	200/200	200/200	200/200	200/200	0/0	0/0	0/0	0/0
Change direction	off	off	off	off	off				
Ripple amplitude	60	60	60	60	60				

DIN-settings:	DIN1	DIN2	DIN3	DIN4	DIN5	DIN6	DIN7	DIN8	DINX
Double push	off	off	off	off	off	off	off	off	off



What is meant by default settings?

Default settings are the preprogrammed values in the GPC. Changing settings replaces these. To restore all settings to the default settings, use *Erase EEPROM*, see chapter 11.7.

What can settings be used for?

The default settings in bank B is a suitable starting point when setting up a four-function system with an actuator, e.g. forklift trucks.

Settings in Logic, Functions

(With automatic configuration and Ax1-Ax4 connected.)

	F1	F2	F3	F4	F5	F6	F7	F8	F9	F10	F11	F12
Ax1	+											
Ax2		+										
Ax5												
Ax6												
Ax3	DIN1											
	DIN2		+									
Ax4	DIN3											
	DIN4			+								
Ax7	DIN5											
	DIN6											
DIN7												
DIN8												
DINX												
F1												
F2												
F3												
F4												
F5												
F6												
F7												
F8												
F9												
F10												
F11												
F12												
Import												

Settings in Logic, Outputs

2:2

		Out1	Out2	Out3	Out4	Out5	Out6	Out7	Out8	Out9
F1	A	✓✓								
	B	✓✓								
F2	A		✓✓							
	B		✓✓							
F3	A			✓✓						
	B			✓✓						
F4	A				✓✓					
	B				✓✓					
F5	A					✓✓				
	B					✓✓				
F6	A									
	B									
F7	A									
	B									
F8	A									
	B									
F9	A									
	B									
F10	A									
	B									
F11	A									
	B									
F12	A									
	B									
DIN1										
DIN2										
DIN3										
DIN4										
DIN5										
DIN6										
DIN7										
DIN8										
DINX										

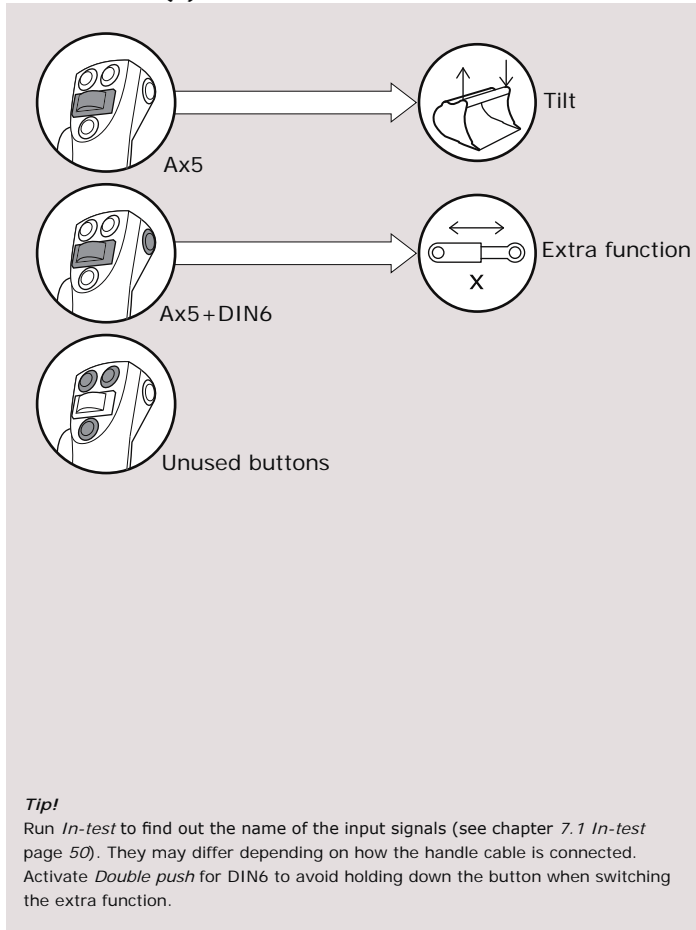
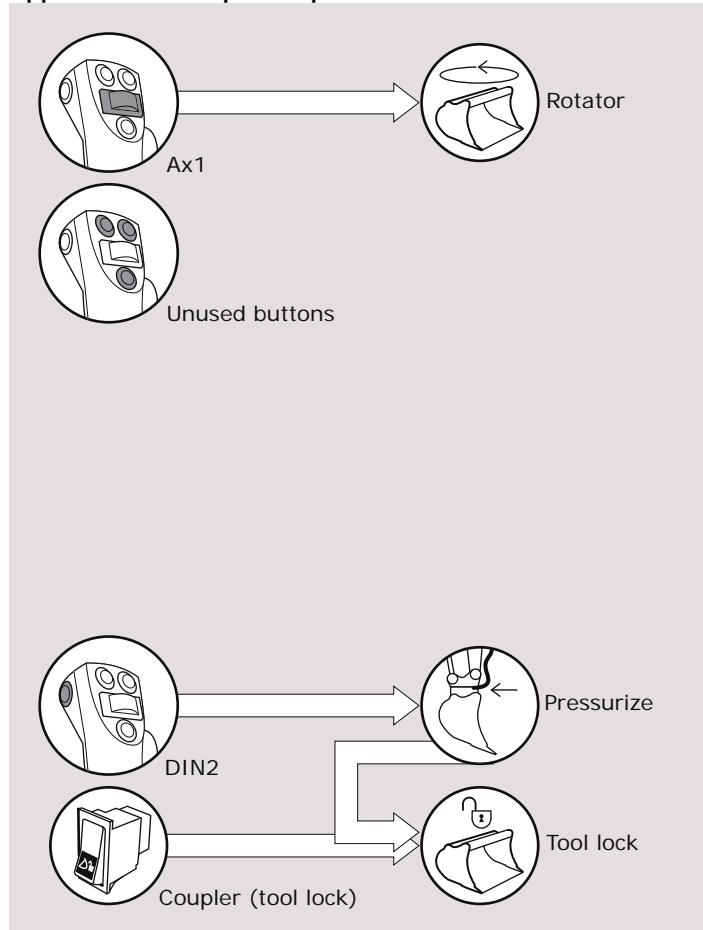

	① - Enter master mode. - Select "Output type". - Set the following:	② - Enter master mode. - Select "Logic", "Functions". - Set the following: (NOTE! Follow instructions exactly)	③ - Enter master mode. - Select "Logic", "Functions". - Set the following: (NOTE! Follow instructions exactly)
Rotator	Out1 V-function	<input type="text" value="F1 Ax1 +"/>	<input type="text" value="Out1 PN F1A ⚡"/> <input type="text" value="Out1 PN F1B ⚡"/>
Tilt	Out2 V-function	<input type="text" value="F2 Ax5 +"/> <input type="text" value="F2 DIN6 #"/>	<input type="text" value="Out2 PN F2A ⚡"/> <input type="text" value="Out2 PN F2B ⚡"/>
Extra function	Out3 On/Off (V-function for prop. valve)	<input type="text" value="F3 Ax5 +"/> <input type="text" value="F3 DIN6 &"/>	<input type="text" value="Out3 PN F3A ⚡"/> <input type="text" value="Out3 PN F3B ⚡"/>
Coupler	Out9 Coupler	no setting	<input type="text" value="Out9 Fee DINX ⚡"/>
Feeder	Out5 Feeder A	no setting	<input type="text" value="Out5 Fee OUT1A ⚡"/> <input type="text" value="Out5 Fee OUT1B ⚡"/> <input type="text" value="Out5 Fee OUT2A ⚡"/> <input type="text" value="Out5 Fee OUT2B ⚡"/> <input type="text" value="Out5 Fee OUT3A ⚡"/> <input type="text" value="Out5 Fee OUT3B ⚡"/> <input type="text" value="Out5 Fee DIN2 ⚡"/>

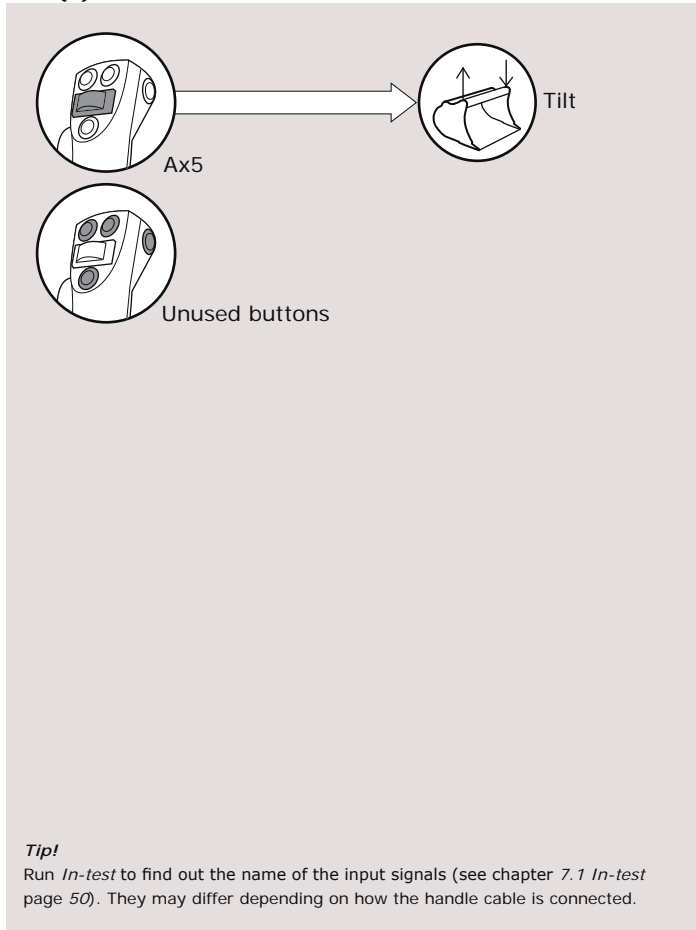
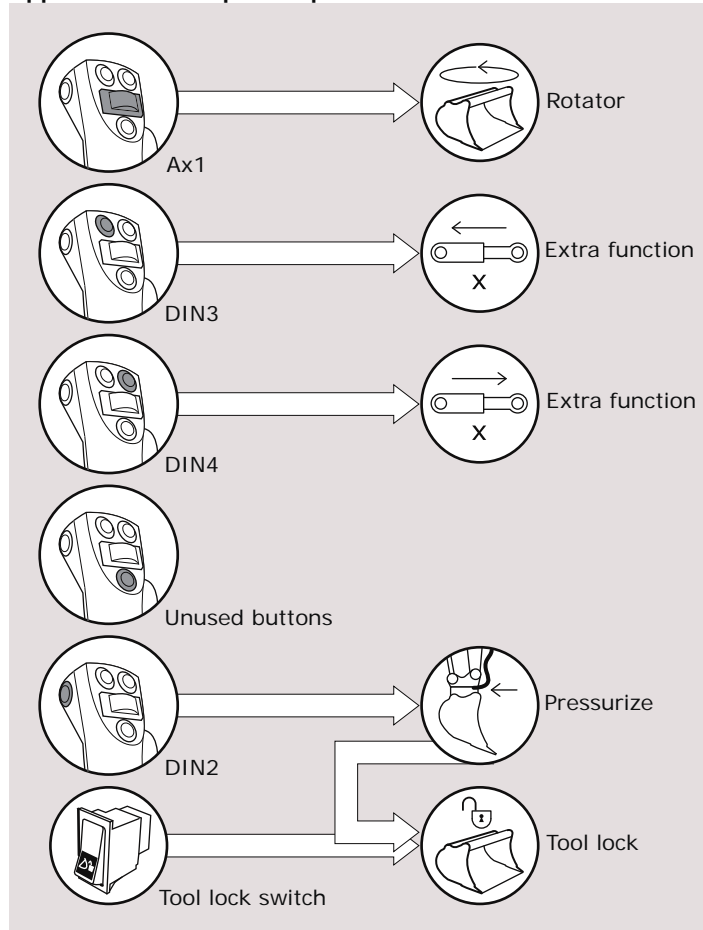

	① - Enter master mode. - Select "Output type". - Set the following:	② - Enter master mode. - Select "Logic", "Functions". - Set the following: (NOTE! Follow instructions exactly.)	③ - Enter master mode. - Select "Logic", "Functions". - Set the following: (NOTE! Follow instructions exactly.)
Rotator	Out1 V-function	F1 Ax1 +	Out1 PN F1A ✓ Out1 PN F1B ✓
Tilt	Out2 V-function	F2 Ax5 +	Out2 PN F2A ✓ Out2 PN F2B ✓
Extra function	Out3 On/Off	F3 DIN3 + F3 DIN4 -	Out3 PN F3A ✓ Out3 PN F3B ✓
Coupler	Out9 Coupler	no setting	Out9 PN DINX ✓
Feeder	Out5 Feeder A	no setting	Out5 Fee OUT1A ✓ Out5 Fee OUT1B ✓ Out5 Fee OUT2A ✓ Out5 Fee OUT2B ✓
			Out5 Fee OUT3A ✓ Out5 Fee OUT3B ✓ Out5 Fee DIN2 ✓

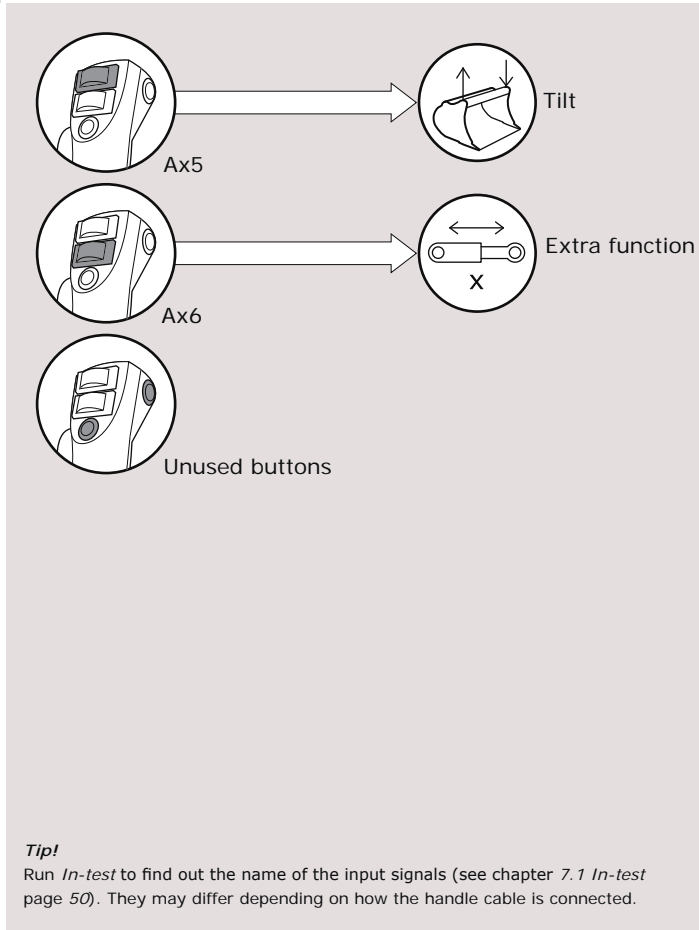
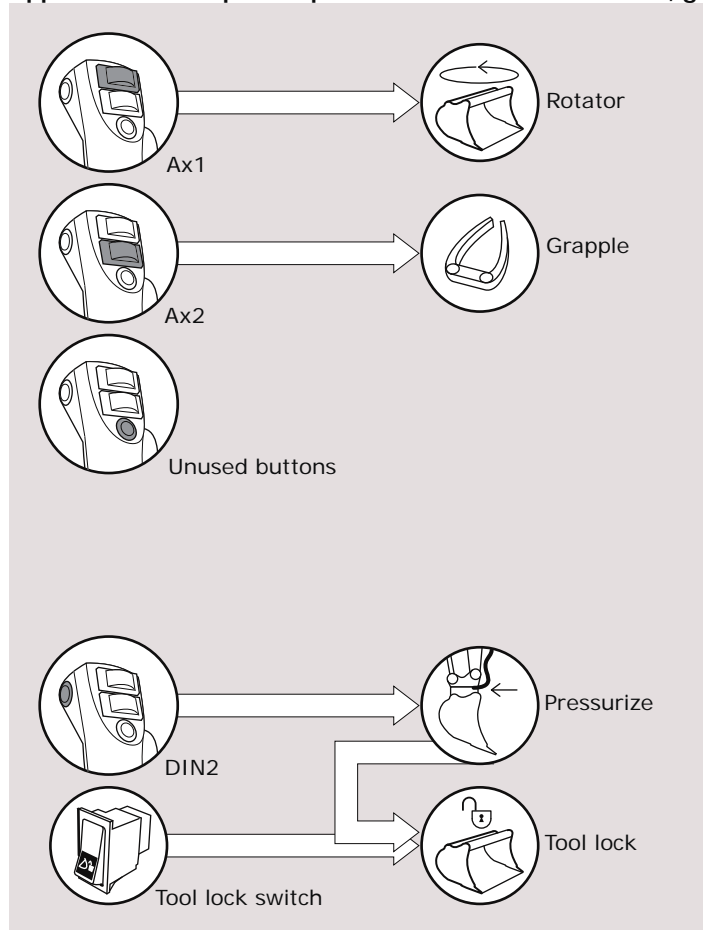

	① - Enter master mode. - Select "Output type". - Set the following:	② - Enter master mode. - Select "Logic", "Functions". - Set the following: (NOTE! Follow instructions exactly.)	③ - Enter master mode. - Select "Logic", "Functions". - Set the following: (NOTE! Follow instructions exactly.)
Rotator	Out1 V-function	F1 Ax1 +	Out1 PN F1A <input checked="" type="checkbox"/> Out1 PN F1B <input checked="" type="checkbox"/>
Tilt	Out2 V-function	F2 Ax5 +	Out2 PN F2A <input checked="" type="checkbox"/> Out2 PN F2B <input checked="" type="checkbox"/>
Grapple	Out3 On/Off (V-function for prop. valve)	F3 Ax2 +	Out3 PN F3A <input checked="" type="checkbox"/> Out3 PN F3B <input checked="" type="checkbox"/>
Extra function	Out4 On/Off (V-function for prop. valve)	F4 Ax6 +	Out4 PN F4A <input checked="" type="checkbox"/> Out4 PN F4B <input checked="" type="checkbox"/>
Coupler	Out9 Coupler	no setting	Out9 PN DINX <input checked="" type="checkbox"/>
Feeder	Out5 Feeder A	no setting	Out5 Fee OUT1A <input checked="" type="checkbox"/> Out5 Fee OUT1B <input checked="" type="checkbox"/> Out5 Fee OUT2A <input checked="" type="checkbox"/> Out5 Fee OUT2B <input checked="" type="checkbox"/> Out5 Fee OUT3A <input checked="" type="checkbox"/> Out5 Fee OUT3B <input checked="" type="checkbox"/> Out5 Fee OUT4A <input checked="" type="checkbox"/> Out5 Fee OUT4B <input checked="" type="checkbox"/> Out5 Fee DIN2 <input checked="" type="checkbox"/>

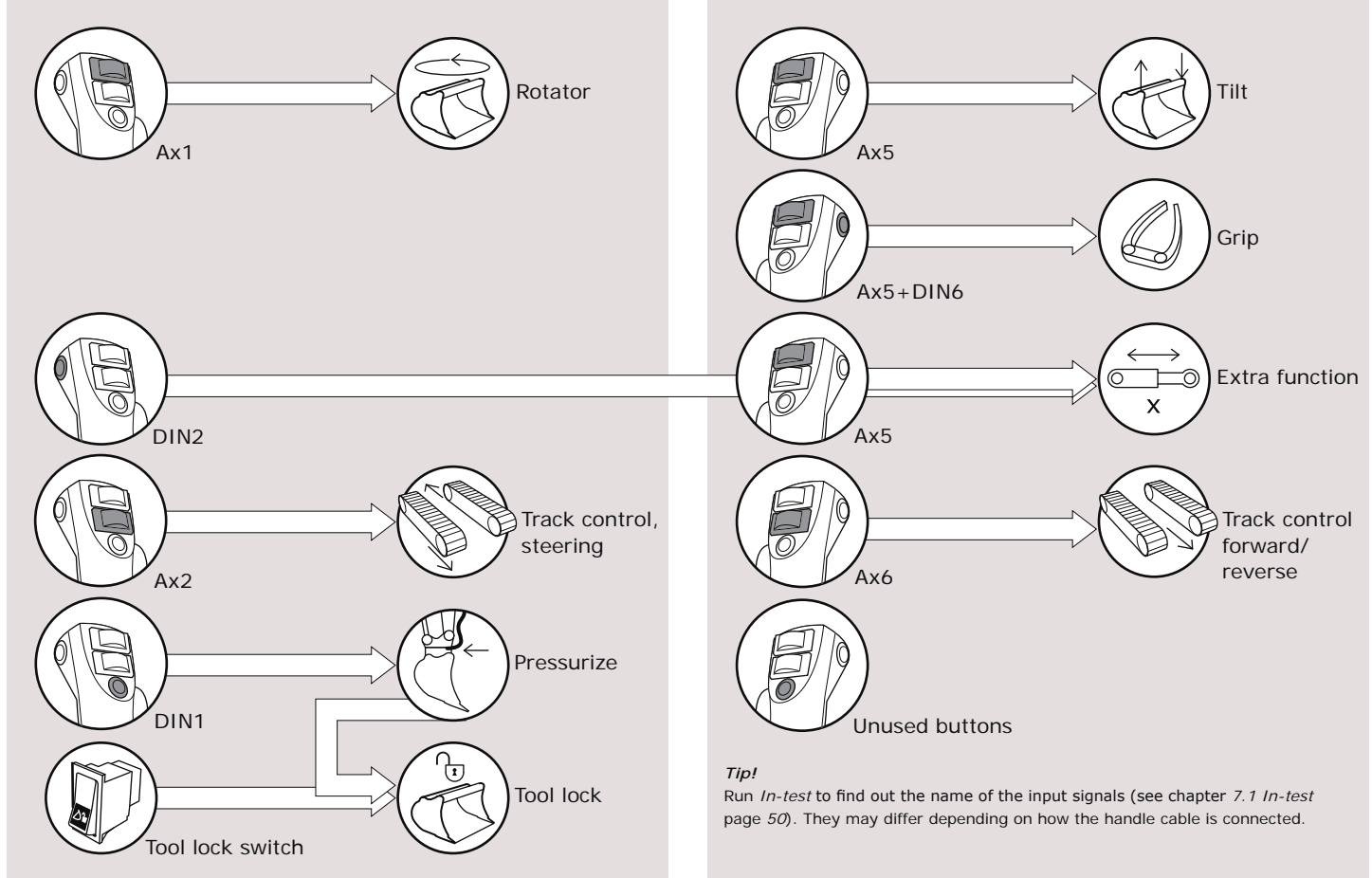

	① - Enter master mode. - Select "Output type". - Set the following:	② - Enter master mode. - Select "Logic", "Functions". - Set the following: (NOTE! Follow instructions exactly.)	③ Enter master mode. - Select "Logic", "Functions". - Set the following: (NOTE! Follow instructions exactly.)
Rotator	Out1 V-function	F1 R&1 +	Out1 PN F1A ✓ Out1 PN F1B ✓
Tilt	Out2 V-function	F2 R&5 + F2 DIN2 # F2 DIN6 #	Out2 PN F2A ✓ Out2 PN F2B ✓
Grapple	no setting	F3 R&5 + F3 DIN2 # F3 DIN6 &	Out6 PN F3A ✓ Out7 PN F3B ✓
Extra function	no setting	F4 R&5 + F4 DIN2 & F4 DIN6 #	Out6 PN F4A ✓ Out7 PN F4B ✓ Out8 PN DIN2 ✓
Track control, steering	Out3 V-function Out4 V-function	F5 R&2 + F6 R&2 -	Out3 PN F5A ✓ Out3 PN F5B ✓ Out4 PN F6A ✓ Out4 PN F6B ✓
Track control, forward/reverse		F7 R&6 +	Out3 PN F7A ✓ Out3 PN F7B ✓ Out4 PN F7A ✓ Out4 PN F7B ✓
Coupler	Out9 Coupler	no setting	Out9 PN DIN4 ✓
Feeder	Out5 Feeder A	no setting	Out5 Pst Out1A ✓ Out5 Pst Out1B ✓ Out5 Pst Out2A ✓ Out5 Pst Out2B ✓ Out5 Pst Out6 ✓ Out5 Pst Out7 ✓ Out5 Pst DIN1 ✓

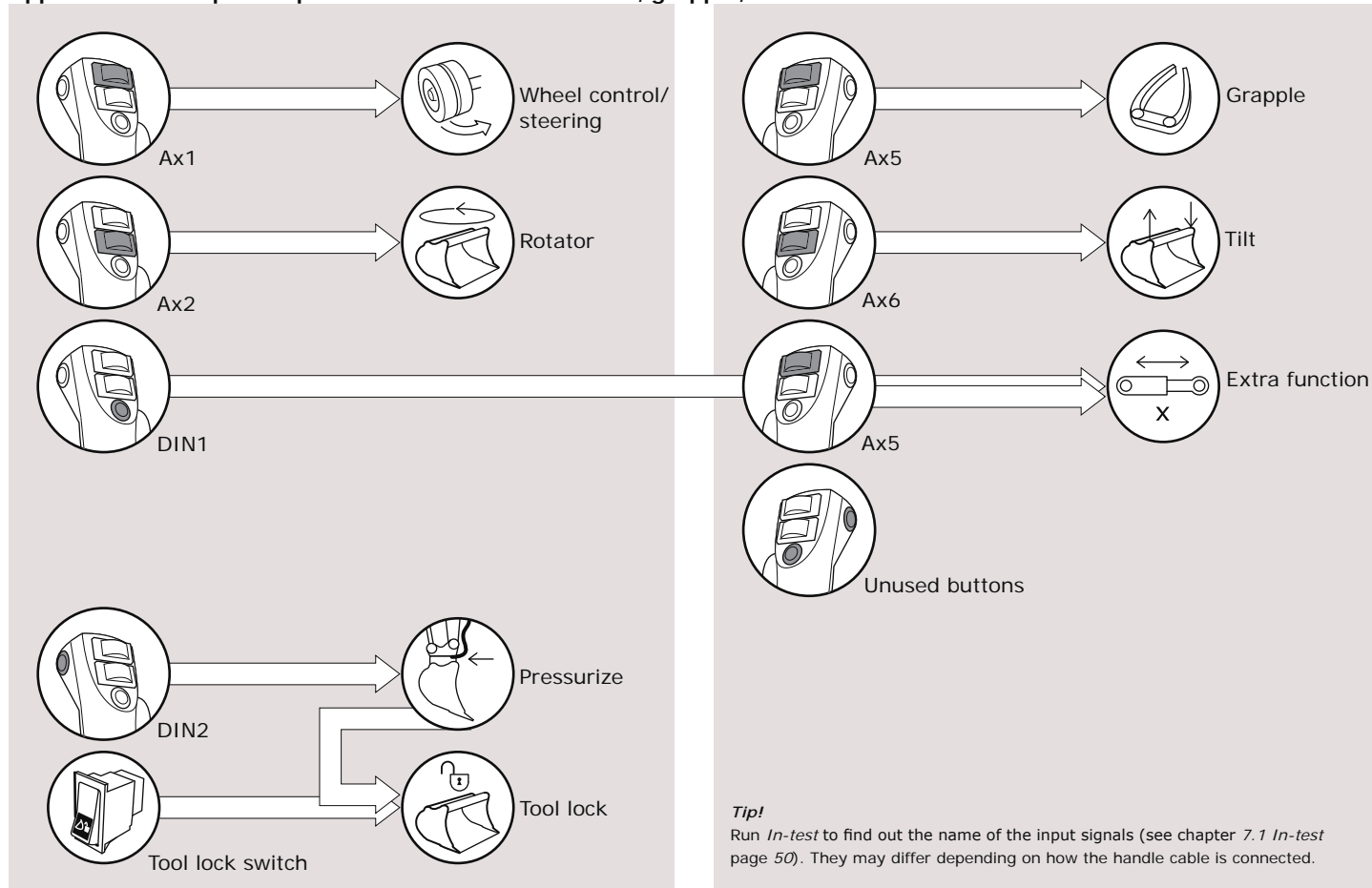

	① - Enter master mode. - Select "Output type". - Set the following:	② - Enter master mode. - Select "Logic", "Functions". - Set the following: (NOTE! Follow instructions exactly)	③ - Enter master mode. - Select "Logic", "Functions". - Set the following: (NOTE! Follow instructions exactly)
Rotator	Out1 V-function	F1 Ax2 +	Out1 PN F1A ∟∟ Out1 PN F1B ∟∟
Tilt	Out2 V-function	F2 Ax6 +	Out2 PN F2A ∟∟ Out2 PN F2B ∟∟
Wheel control	Out3 Single A	F3 Ax1 +	Out3 PN F3A ∟∟ Out3 PN F3B ∟∟ Out6 PN F3A ∟∟ Out7 PN F3B ∟∟
Grapple	Out4 On/Off (V-function for prop. valve)	F4 Ax5 + F4 DIN1 #	Out4 PN F4A ∟∟ Out4 PN F4B ∟∟
Extra function	no setting	F5 Ax5 + F5 DIN1 &	Out4 PN F5A ∟∟ Out4 PN F5B ∟∟ Out8 PN F5A ∟∟ Out8 PN F5B ∟∟
Coupler	Out9 Coupler	no setting	Out9 PN DINX ∟∟
Feeder	Out5 Feeder A	no setting	Out5 Fee OUT1A ∟ Out5 Fee OUT1B ∟ Out5 Fee OUT2A ∟ Out5 Fee OUT2B ∟ Out5 Fee OUT4A ∟ Out5 Fee OUT4B ∟ Out5 Fee DIN2 ∟

Declaration of Conformity

The manufacturer declares that the product complies with the requirements in

EMC directive 89/336/EC

CE directive 93/68 EC

Safety directive EN954-1 Category 3

Type of Equipment: Control system for mobile use

Brand Name: GP Controller

Manufacturer: SVAB Hydraulik AB

Address: Ulvsättersgatan 2
SE-694 91 Hallsberg, SWEDEN

Phone: +46 582 15230

Fax: +46 582 15232

E-mail: info@svab.se

The manufacturer within EU/EES declares under sole responsibility that this product complies with the requirements in the aforementioned standard directives.

SVAB Hydraulik



Kent Bengtsson

MENU REGISTER



Main menu

	Page:
Return	
End levels.....	28, 72
Start levels.....	28, 71
Feeder settings	
Return	
End levels	28, 66
Start levels	29, 65
Max levels	29, 68
Fixed levels	30, 67
Ramp time	30, 78
Derivation	31, 82
Middle level.....	31, 64
Information	
Return	
Firmware version	32, 95
Serial number	32, 95
Show stored error codes	32, 94
Erase stored error codes	33, 94
Middle levels	33, 69
Ramp time	34, 78
Progressive curve	34, 77
Lever calibration	35, 74
Change direction	35, 82
Copy banks	35, 88
Enter code/Unlock menus	36, 84



Master mode

	Page:
Return	
Logic	38, 49
Return	
In-test	38, 50
Functions	38, 51
Outputs	39, 96
Double push	39, 59
Output type	40, 44
Ripple amplitude	40, 81
Lever calibration	40, 74
Hysteresis	41, 76
Erase EEPROM	41, 95
Buzzer	41, 83

To enter the main menu:

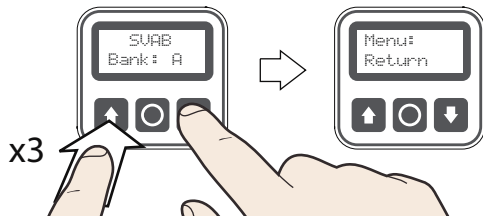

Press the following combination to access the master mode menu:



Welcome to contact us if you need help or answers to questions

Orderdesk

+46 582-152 30, press 1 in the switchboard
info@svab.se

Sales

+46 582-152 30, press 1 in the switchboard
order@svab.se

Support

+46 582-152 30, press 2 in the switchboard
support@svab.se

www.svab.se

The logo for SVAB, consisting of the letters 'S', 'V', 'A', and 'B' in a bold, blue, sans-serif font. The letters are closely spaced and have a slight shadow effect.